

NOTES:

- 1.) MAT'L: .025 THICK, BEARING BRONZE, #4 TEMPER (FULL HARD)
PER ETCO METAL CODE 03380.
- 2.) MAT'L: .025 THICK, PHOSPHOR BRONZE, #4 TEMPER (FULL HARD)
PER ETCO METAL CODE 03640.
- 3.) MAT'L: .025 THICK, COPPER PLATED STEEL, #2 TEMPER (HALF HARD)
PER ETCO METAL CODE 02820.
- 4.) WIRE RANGE: 14-18 AWG.

Rev.	Description of Change/ SCN#	Date
1	REDRAWN ON SOLIDWORKS NO CHANGES SCJ ORG.ENG.DWG.DATE: 1-2-80	3-14-08
2	COMPLTETED P/C LIST SCJ	7-23-08

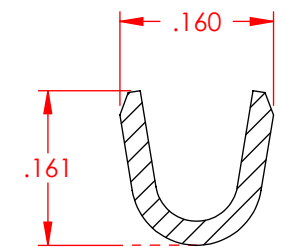
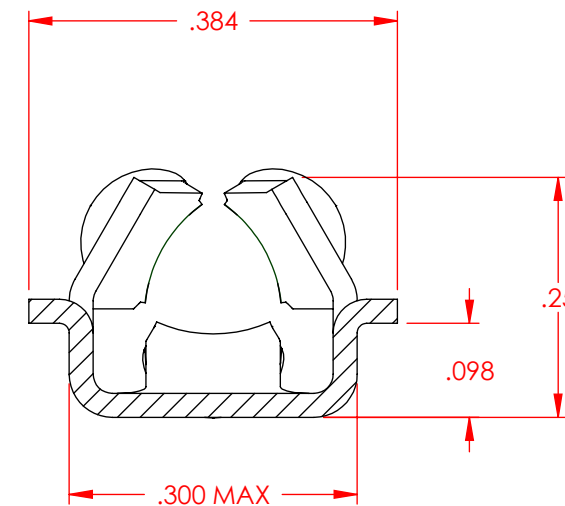
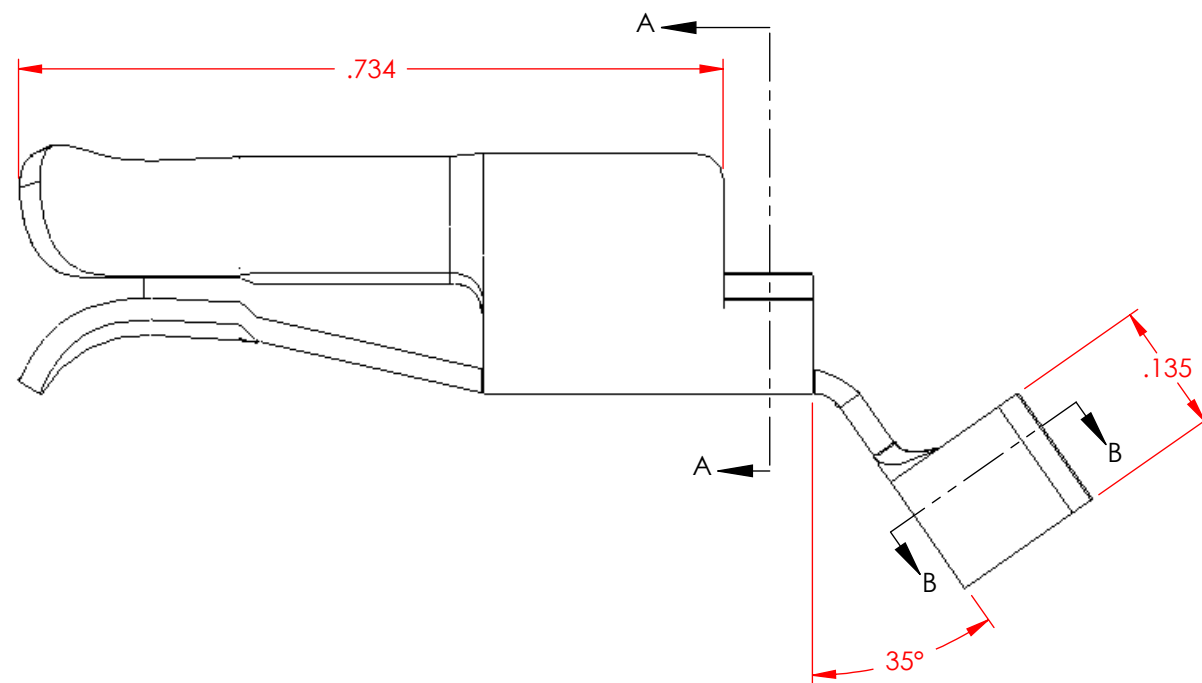
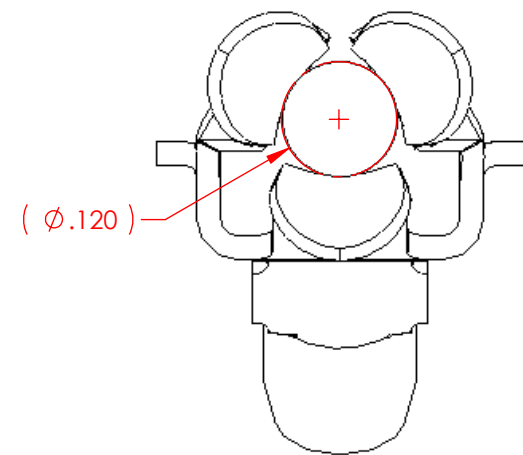
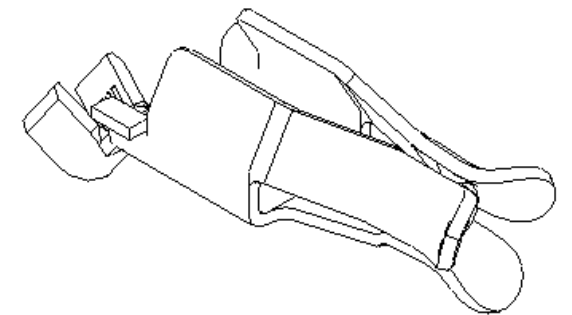
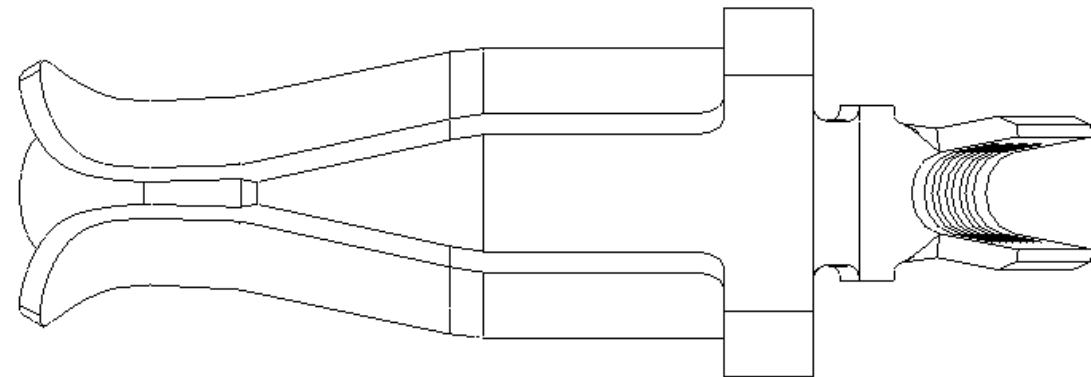

SECTION A-A
SCALE 5 : 1

SECTION B-B
SCALE 5 : 1

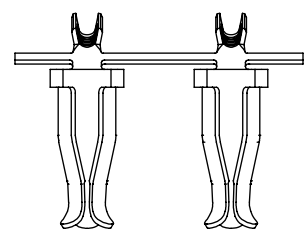

DIRECTION EXITING TOOL,
EARS UP, TO THE BACK

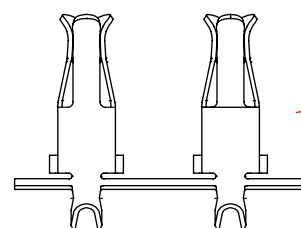

TWIST PARTS 180°,
EARS UP, TO THE FRONT,
WIND OVER REEL

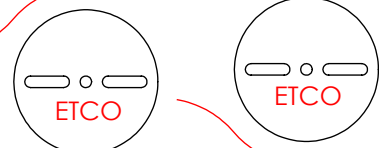

DIRECTION TOWARD APPLICATOR,
EARS UP, TO THE FRONT

THIS PRINT IS THE PROPERTY OF ETCO INCORPORATED. NO PART OF THIS DESIGN MAY BE USED IN ANY WAY WITHOUT WRITTEN CONSENT FROM ETCO INCORPORATED.

UNCONTROLLED COPY

<p>THIRD ANGLE PROJECTION TOLERANCES UNLESS OTHERWISE SPECIFIED INCHES: .XX - ±.030 .XXX - ±.015 ANGLES: ±5°</p>	<p>TOOL NO. 0207</p>	<p>Title: RECEPTACLE, HEATER CORD CONNECTOR</p>		
		<p>DO NOT SCALE DWG.</p>	<p>Drawn By: S.JOHNSON</p>	<p>Date: 3-14-08</p>
<p>ETCO Incorporated Engineered Products 25 Bellows Street Warwick, RI 02888 Phone: (401) 467-2400 Fax: (401) 467-9230 www.ETCO.com</p>		<p>Chk'd/App'd By:</p>	<p>Scale: 5X</p>	<p>Size B</p>
<p>Dwg. No.: HCRS-187A cust</p>				