

NOTES:

1. MATERIAL: .058 THICK C26000 BRASS; 1/4 HARD, ANNEALED TO TEMPER, PER ETCO METAL CODE 07031.
2. PART CODE 82060 TO BE POST BRIGHT TIN PLATED, .00010-.00030 THICK
3. PARTS MAY BE COATED WITH A LIGHT FILM OF LUBRICATION USED IN THE MANUFACTURING PROCESS.
4. WIRE RANGE: #10-#16 AWG.
5. NEMA L5-20, 125 VOLTS-20 AMPS.

P/C	DESCRIPTION	MAT'L	PLATING
82050	MALETLGRD-HB	NOTE 1	NONE
82060	MALETLGRD-HB-TAF	NOTE 1	NOTE 2

Rev.	Description of Change/ SCN#	Date
-	INITIAL RELEASE SCJ	1-24-07

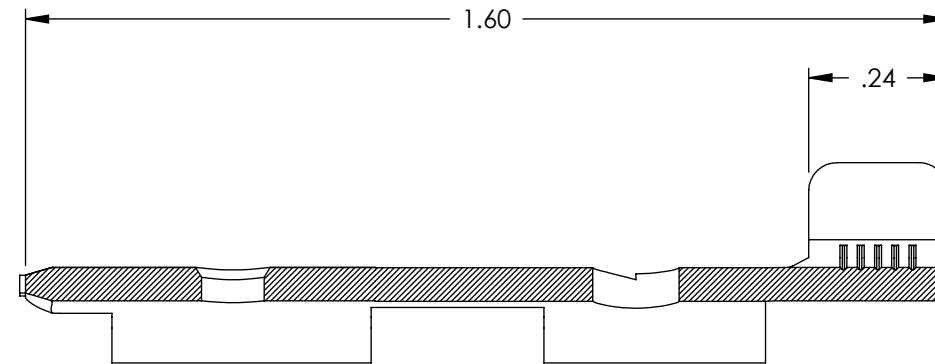
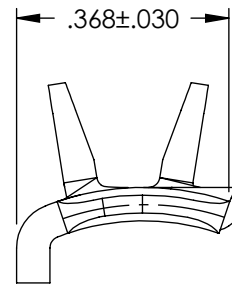
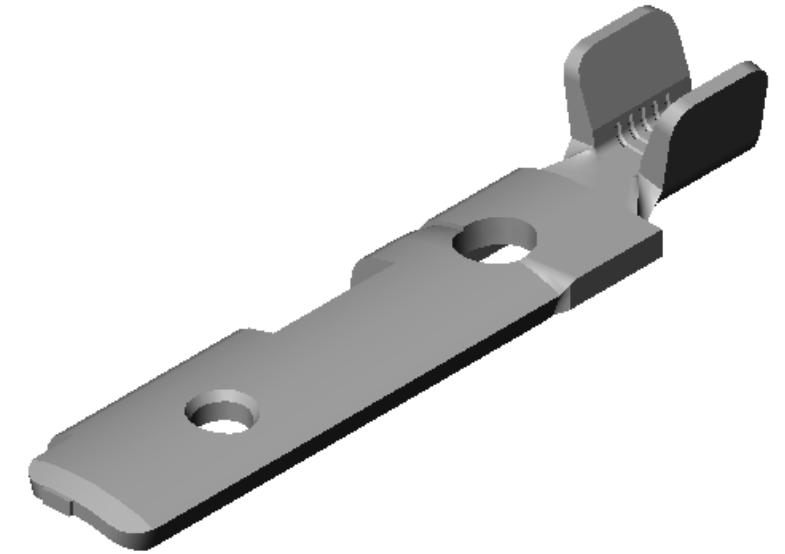
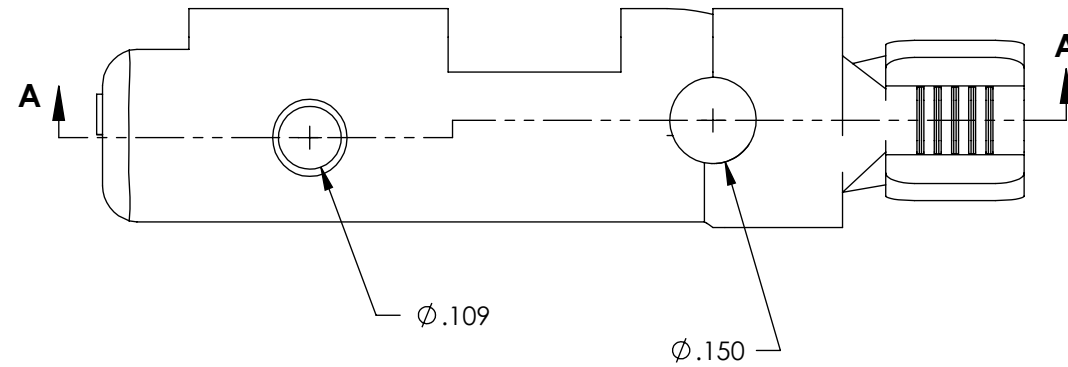

SECTION A-A

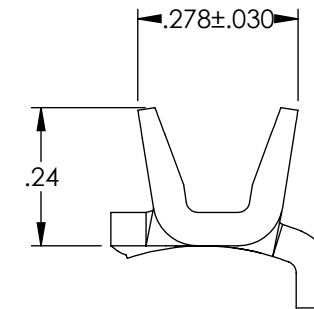

UNCONTROLLED COPY

<p>THIRD ANGLE PROJECTION TOLERANCES UNLESS OTHERWISE SPECIFIED INCHES: .XX - ±.030 .XXX - ±.015 ANGLES: ±5°</p>	<p>TOOL NO. 0835</p>	<p>Title: MALE TWIST LOCK TERMINAL: L5-20, 125 VOLTS-20 AMPS.</p>		
		<p>DO NOT SCALE DWG.</p>	<p>Drawn By: S.JOHNSON</p>	<p>Date: 1-24-07</p>
<p>ETCO Incorporated Engineered Products 25 Bellows Street Warwick, RI 02888 Phone: (401) 467-2400 Fax: (401) 467-9230 www.ETCO.com</p>		<p>Chk'd/App'd By:</p>	<p>Scale: 3X</p>	<p>Size B</p>
<p>Dwg. No.: MALETLGRD cust</p>				