

NOTE:

- 1.) MAT'L: .058 THK., BRASS, #1 TEMPER (QUARTER HARD), ANNEALED TO TEMPER, PER ETCO METAL CODE NO. 07025.
- 2.) PARTS MAY BE COATED WITH A LIGHT FILM OF LUBRICATION USED IN THE MANUFACTURING PROCESS.
- 3.) WIRE RANGE: 10-16 AWG.
- 4.) NEMA L7-15, 277 VOLTS-15 AMPS.

P/C	DESCRIPTION (4)	MAT'L
82082	MALETLGRD-V2-D-HB	NOTE 1

Rev.	Description of Change/ SCN#	Date
1	TRANSFER FROM CP TO EP	1-18-05
2	SCN# 102830 SCJ	1-24-05
3	ECR# 533 JMR	12-07-10
4	ECR# 816 SCJ	11-3-11

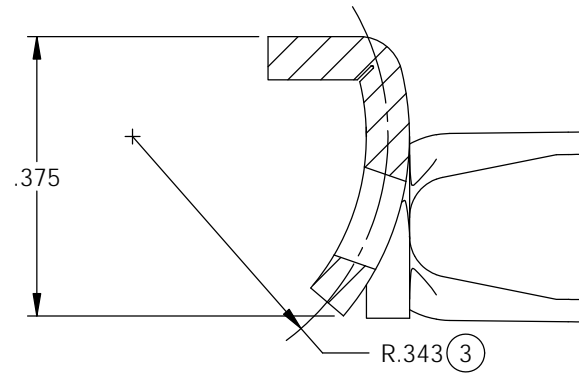

SECTION B-B
SCALE 4 : 1

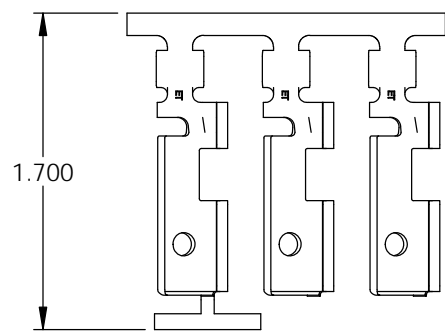
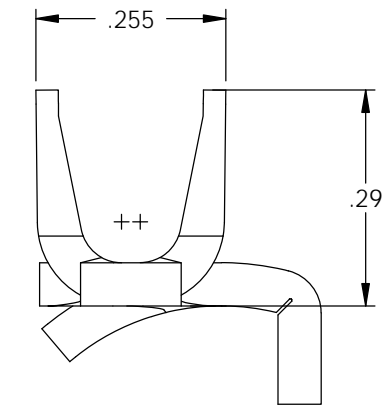
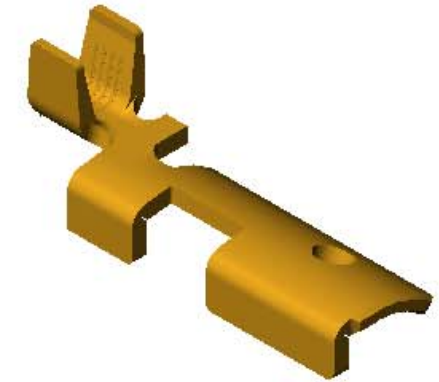
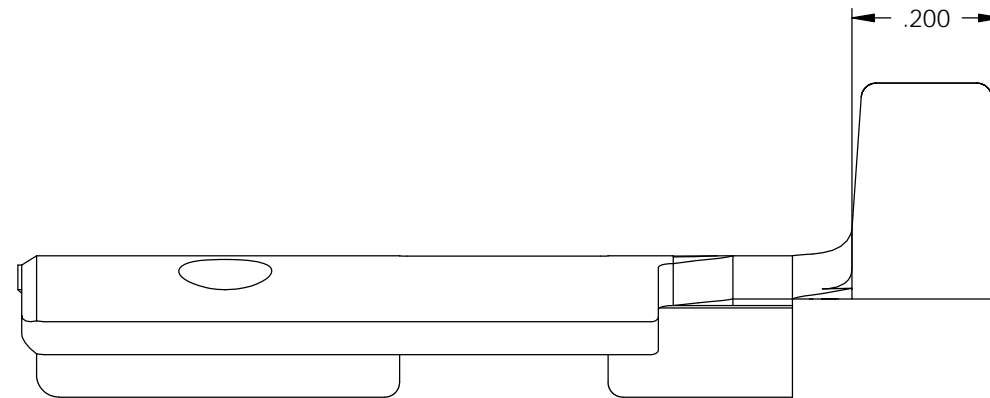
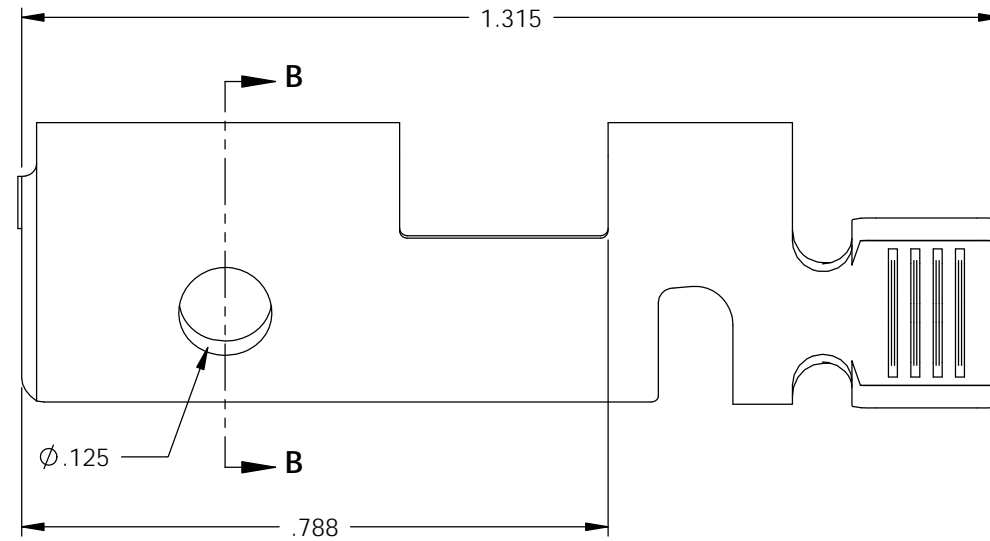

DIRECTION EXITING TOOL,
EARS DOWN, TO THE BACK

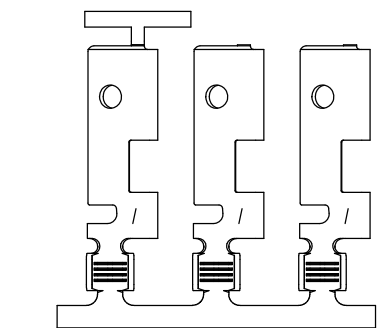
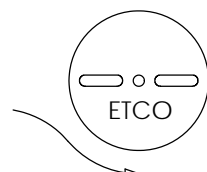
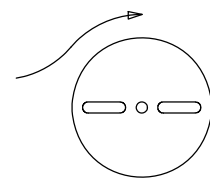

DIRECTION TOWARD APPLICATOR,
EARS UP, TO THE FRONT

THIS PRINT IS THE PROPERTY OF ETCO INCORPORATED. NO PART OF THIS DESIGN MAY BE USED IN ANY WAY WITHOUT WRITTEN CONSENT FROM ETCO INCORPORATED.

UNCONTROLLED COPY

<p>THIRD ANGLE PROJECTION</p>	<p>TOOL NO. 0847</p>	<p>Title: MALE TWIST GROUND: L7-15, 277 VOLTS-15 AMPS</p>			
		<p>DO NOT SCALE DWG.</p>	<p>Drawn By: S. JOHNSON</p>	<p>Date: 1-18-05</p>	
<p>TOLERANCES UNLESS OTHERWISE SPECIFIED</p> <p>INCHES: .XX - ±.030 .XXX - ±.015</p> <p>ANGLES - ±5°</p>	<p>ETCO</p>	<p>ETCO Incorporated Engineered Products 25 Bellows Street Warwick, R.I. 02888 Phone: (401)467-2400 FAX: (401)467-9230 www.ETCO.com</p>	<p>Chk'd/App'd By:</p>	<p>Scale: 4:1</p>	<p>Size B</p>
<p>Dwg. No.: MALETLGRD-V2</p>					