



REFERENCE LIST:
S215
ECC APPLICATOR
BILL OF MATERIAL NUMBER
79786

WARNING !
NEVER OPERATE
THIS OR ANY
APPLICATOR
WITHOUT SAFETY
GUARD IN POSITION.

PART CODE	PART NUMBER	QUANTITY	DESCRIPTION
75496	1101-FS	(1)	PLUNGER
77918	1102-FS	(1)	FLOATING SHANK
75729	1156	(1)	CUT-OFF SCREW
75728	1155	(1)	ADJUST SCREW
75724	1150	(1)	INSULATION BLOCK
75710	1125	(1)	CAM ROLLER BRACKET
75719	1142	(1)	CAM ROLLER BEARING
71695	*12-140	(1)	CUT-OFF PUNCH
72749	*13D-240/260	(1)	WIRE ROLLING TOOL
		N/A	INSULATION ROLLING TOOL
75115	314-R17	(1)	CAM
74403	311	(1)	SPRING PIN
74404	312	(1)	CAM TAPER PIN
74402	310	(1)	CAM RETURN SPRING
73899	101	(1)	TOP CASTING
76969	169	(2)	UNIVERSAL GIBS
74675	406	(1)	COTTER PIN
74676	407	(1)	BRAKE SPRING
77286	408-.687	(1)	BRAKE BUSHING
74674	405	(1)	TAPER PIN
74673	404	(1)	BRAKE CAM
74498	403-1	(1)	BRAKE BODY
74496	402	(1)	SPRING RETAINER
74495	401	(1)	BRAKE SHAFT
74396	306	(1)	FEED FINGER STOP
74393	305	(1)	FEED FINGER ARM
74400	308	(1)	FEED SHAFT
77269	304-.375	(1)	REAR SPACER
76859	307-6	(1)	SPRING
75601	7A-R220-A	(1)	FEED FINGER
		N/A	FRONT SPACER
76858	301-3	(1)	SHOULDER SCREW
73952	231	(2)	STRIPPER SPRING
74813	1600-292	(1)	WIRE STRIPPER / STOP
73955	235	(1)	GUIDE SPACER BLOCK
75010	512	(1)	REAR / RIGHT GUIDE
75392	1000	(1)	FRONT / LEFT GUIDE
74279	254	(1)	DIE PLATE

**NOTE: ITEMS MARKED WITH AN *
 ARE HIGH WEAR ITEMS**

BASE PLATE ASSEMBLY
SIDE FEED
S215, S225

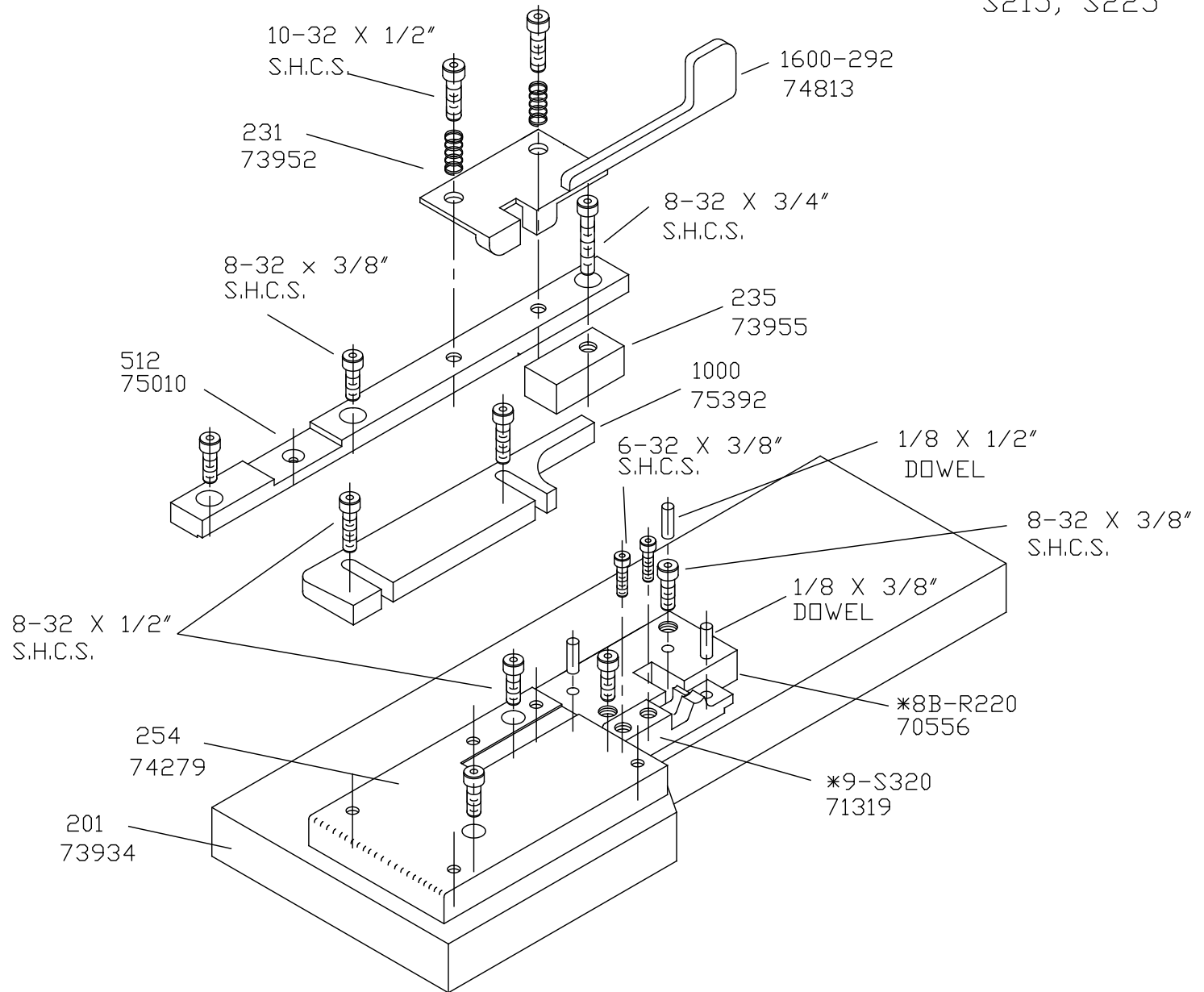

CASTING ASSEMBLY
SIDE FEED
S215, S225

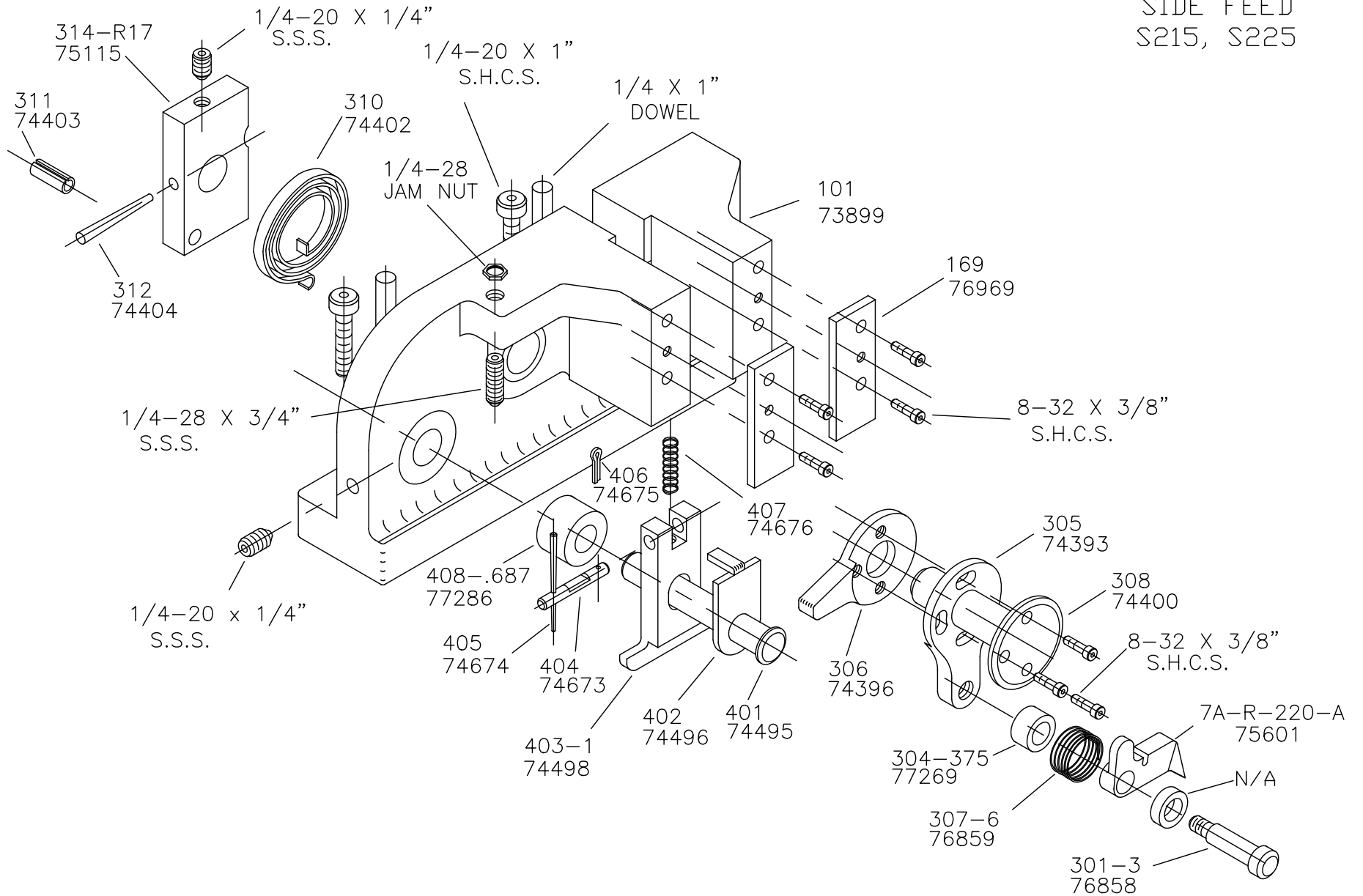

CHUTE AND GUARD S215, S225

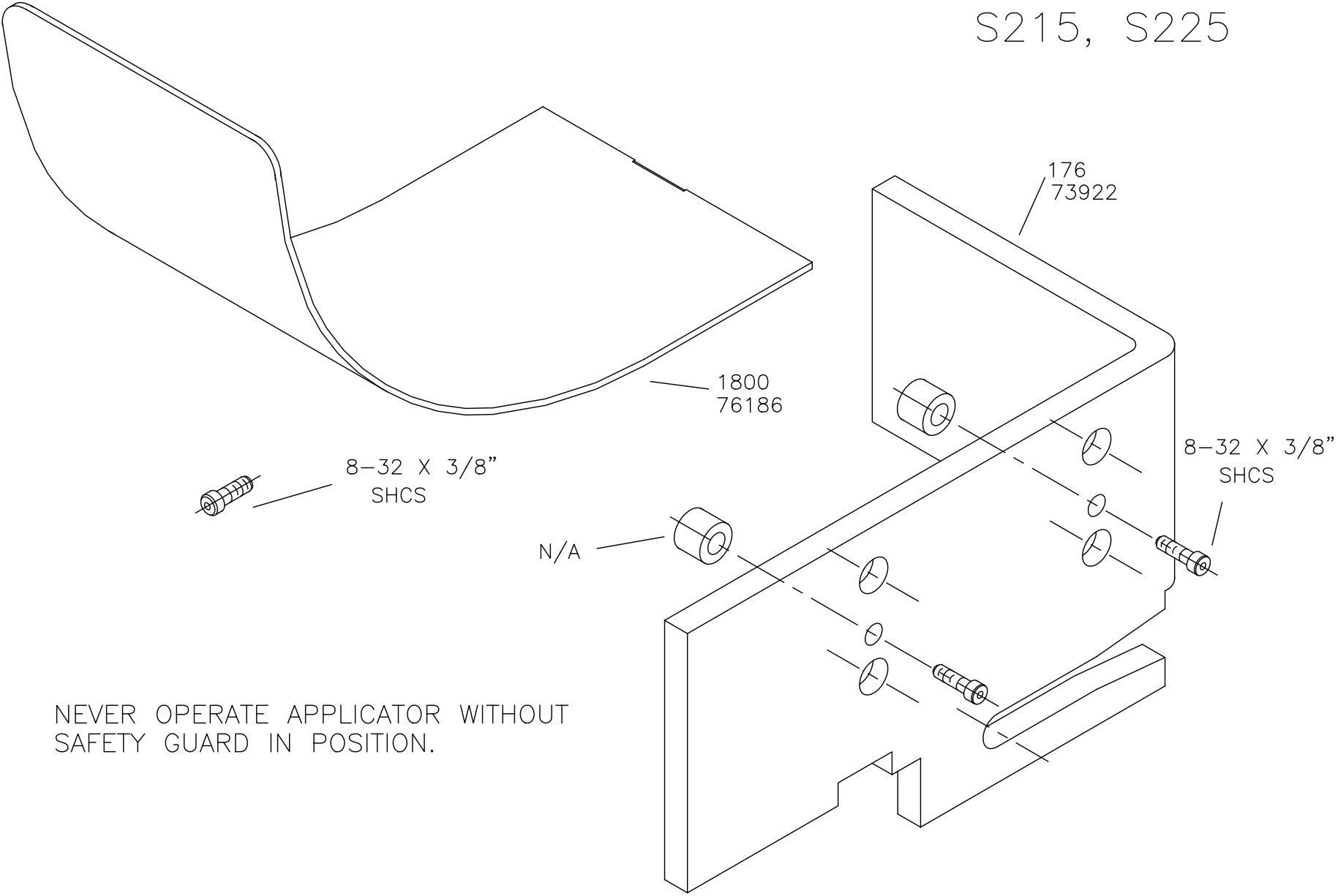

NEVER OPERATE APPLICATOR WITHOUT
SAFETY GUARD IN POSITION.

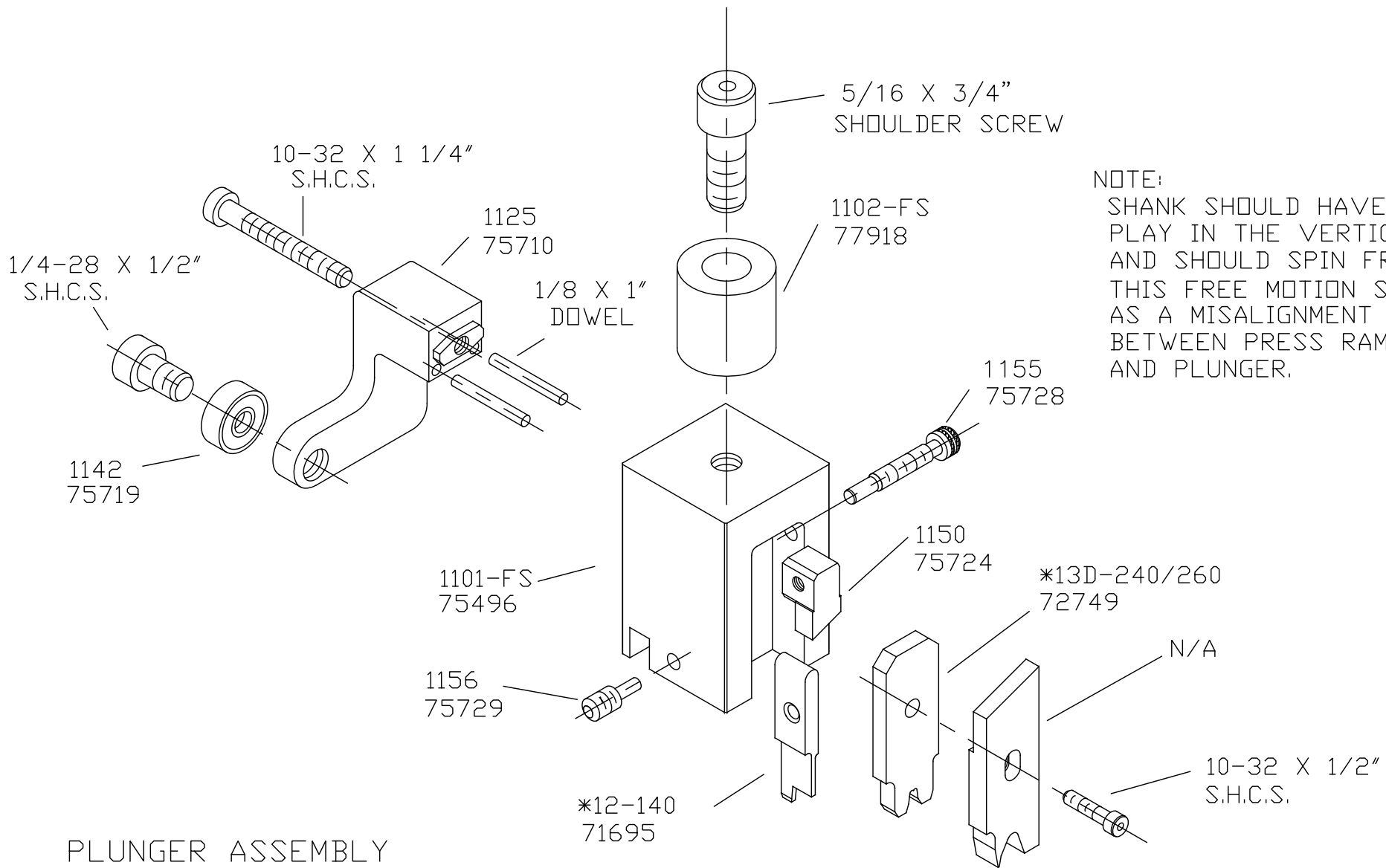

NOTE:
 SHANK SHOULD HAVE FREE
 PLAY IN THE VERTICAL AXIS
 AND SHOULD SPIN FREELY.
 THIS FREE MOTION SERVES
 AS A MISALIGNMENT COUPLING
 BETWEEN PRESS RAM
 AND PLUNGER.

PLUNGER ASSEMBLY
 SIDE FEED
 S215