

NOTES:

1. MATERIAL: .020 THICK 430 STAINLESS STEEL, BRIGHT ANNEALED, PER ETCO METAL CODE 0-0114.
2. MATERIAL: .020 THICK 340 STAINLESS STEEL, ANNEALED TO TEMPER, PER ETCO METAL CODE 0-0089.
3. MATERIAL: .020 THICK C260 BRASS, #3 TEMPER (3/4 HARD), PER ETCO METAL CODE 0-0125.
4. PARTS MAY BE COATED WITH A LIGHT FILM OF LUBRICATION USED IN THE MANUFACTURING PROCESS.
5. WIRE RANGE: 7mm.

P/C	DESCRIPTION	MAT'L	CLIP
15188	DT975-SS-NT	NOTE 1	SCA209

Rev.	Description of Change/ SCN#	Date
1	Redrawn in SolidWorks SCJ Org.Eng.Dwg.Date 3/06/15	4/03/18

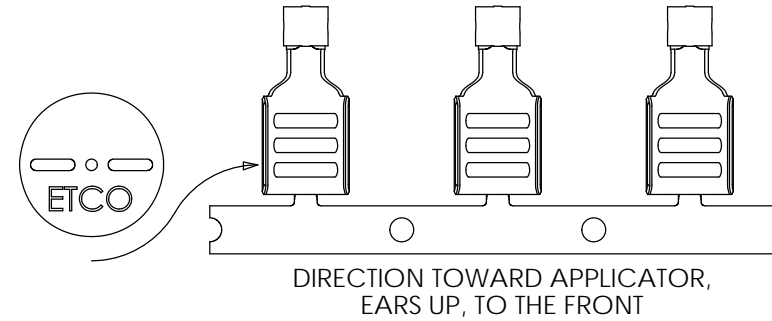
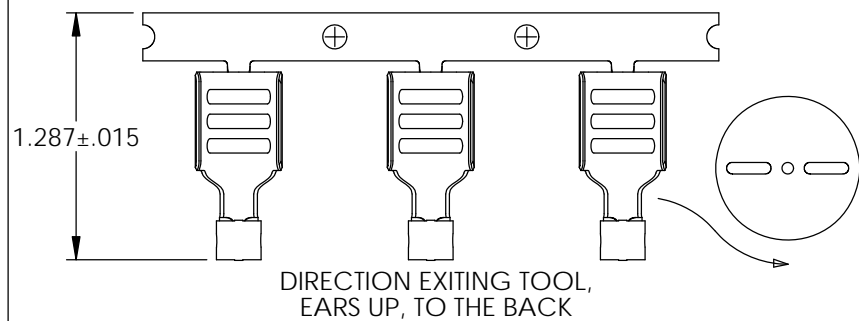
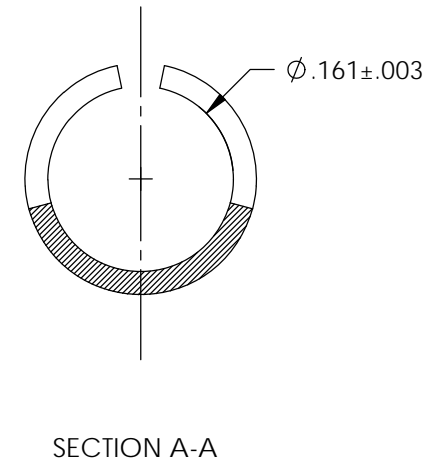
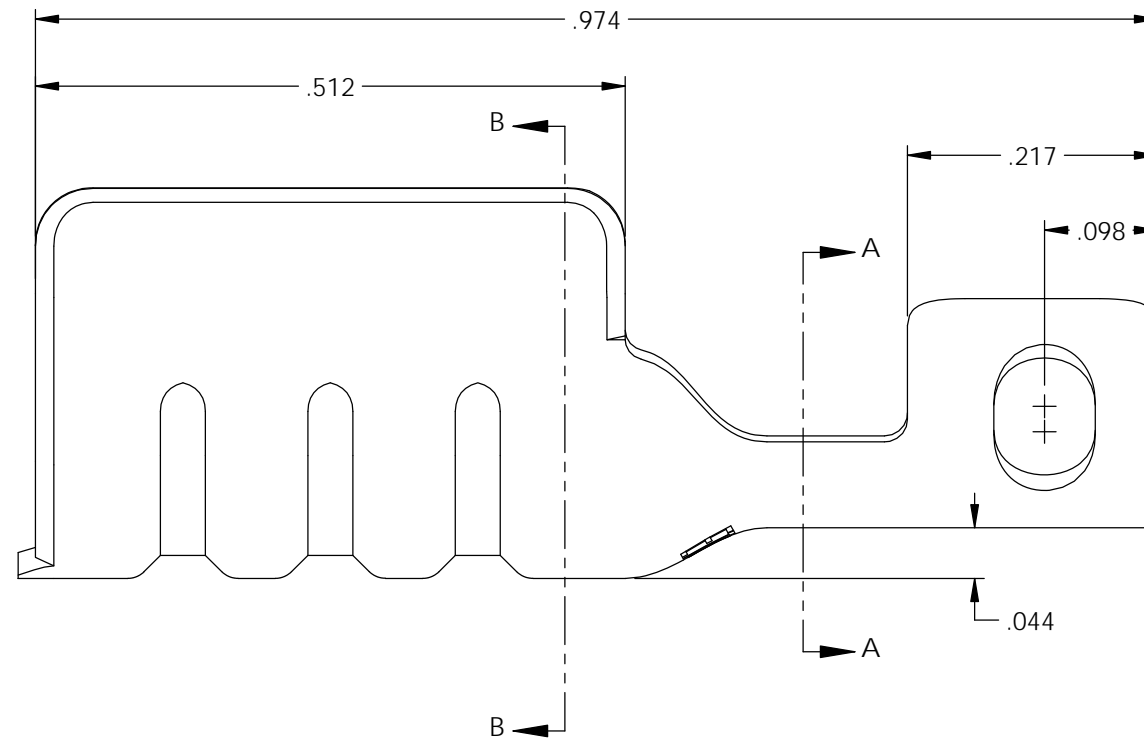
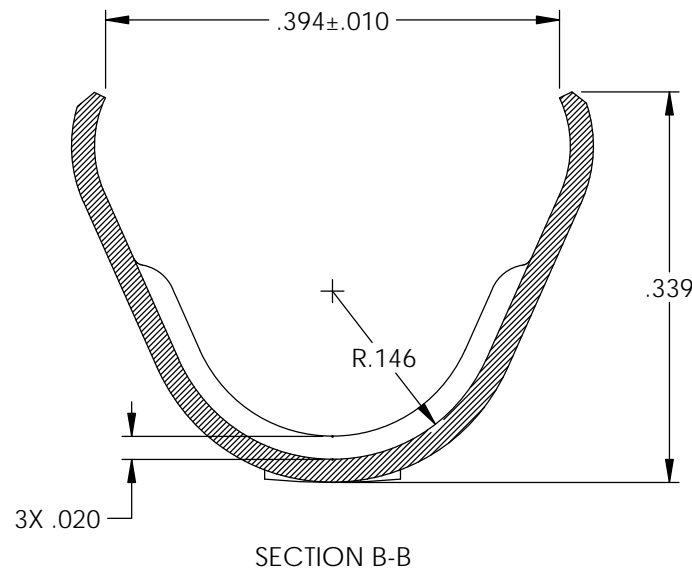
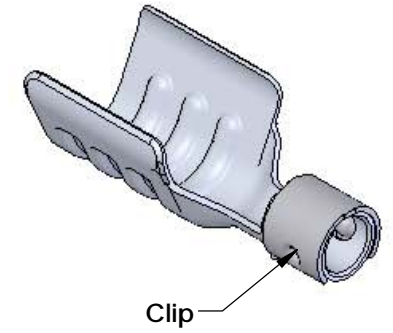
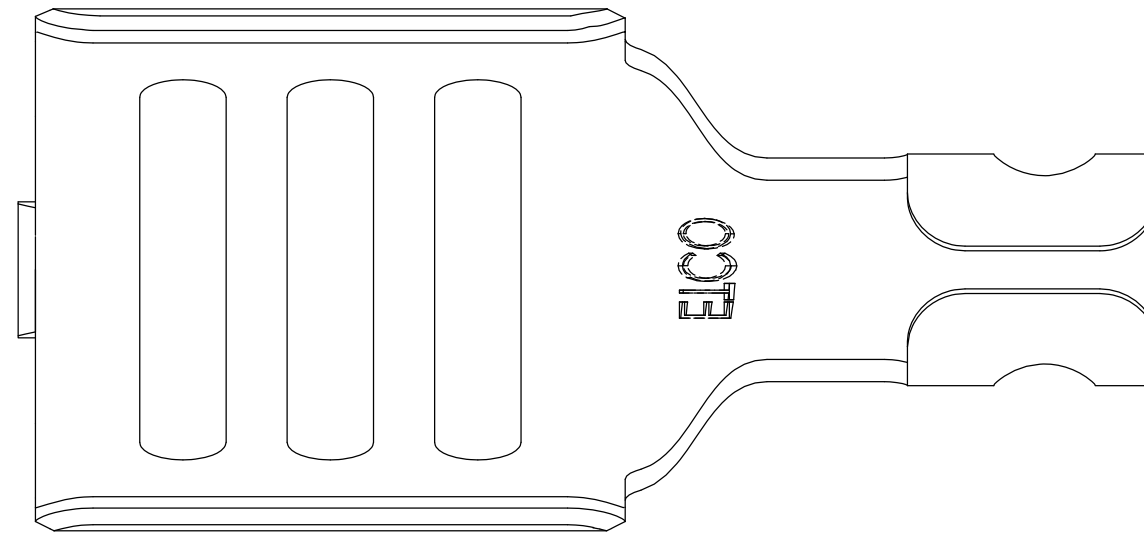

# UNCONTROLLED COPY

<p>THIRD ANGLE PROJECTION TOLERANCES UNLESS OTHERWISE SPECIFIED INCHES: .XX - ±.012 .XXX - ±.006 ANGLES: ±2°</p>	<p>TOOL NO. 2239 2131</p>	<p>Title: <b>Distributor Terminal</b></p>		
		<p>DO NOT SCALE DWG.</p>	<p>Drawn By: S.Johnson</p>	<p>Date: 4/03/18</p>
<p>ETCO Incorporated Engineered Products 25 Bellows Street Warwick, RI 02888 Phone: (401) 467-2400 Fax: (401) 467-9230 www.ETCO.com</p>		<p>Design Control By: ETCO</p>	<p>Scale: 6X</p>	<p>Size B</p>
<p>Dwg. No.: <b>DT975-NT cust</b></p>				