

NOTE:

- 1.) MAT'L: .020 THK., BRASS, #2 TEMPER (HALF HARD), PER ETCO METAL CODE NO. 00390.
- 2.) MAT'L: .020 THK., PRE-TINNED BRASS, #2 TEMPER (HALF HARD), PER ETCO METAL CODE NO. 01450.
- 3.) MAT'L: .020 THK., PRE-NICKEL PLATED STEEL, #3 TEMPER (QUARTER HARD), PER ETCO METAL CODE NO. 03250.
- 4.) MAT'L: .020 THK., COPPER PLATED STEEL, #2 TEMPER (HALF HARD), PER ETCO METAL CODE NO. 02790.
- 5.) PARTS MAY BE COATED WITH A LIGHT FILM OF LUBRICATION USED IN THE MANUFACTURING PROCESS.
- 6.) WIRE RANGE: 16-14 AWG.
- 7.) INSUL RANGE:  $\phi$ .120-.187

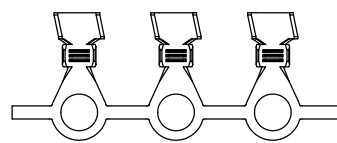

DIRECTION EXITING TOOL, EARS UP, TO THE BACK

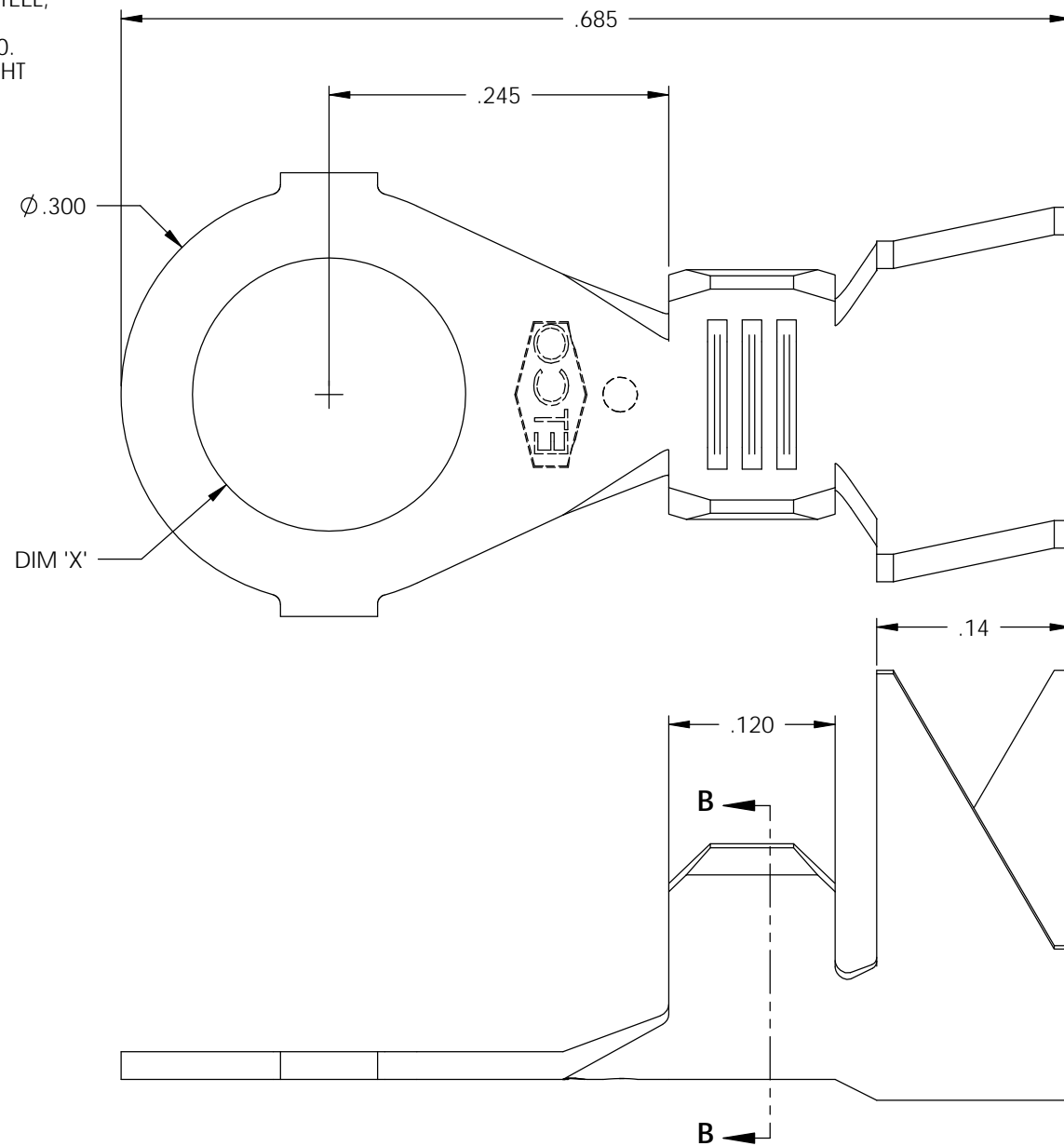
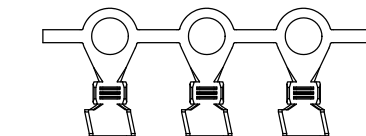
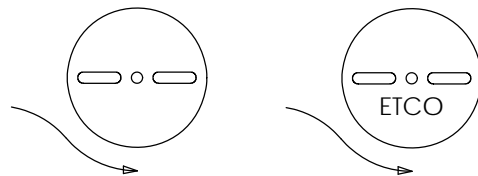

DIRECTION TOWARD APPLICATOR, EARS UP, TO THE FRONT

THIS PRINT IS THE PROPERTY OF ETCO INCORPORATED. NO PART OF THIS DESIGN MAY BE USED IN ANY WAY WITHOUT WRITTEN CONSENT FROM ETCO INCORPORATED.

P/C	DESCRIPTION	DIM 'X'	MAT'L	UL	SP
01728	R188-099-THB	$\phi$ .099	NOTE 2		
01729	R188-099-HB	$\phi$ .099	NOTE 1		
01730	R188-4-HB	$\phi$ .119	NOTE 1	X	X
01741	R188-4-THB	$\phi$ .119	NOTE 2	X	X
01750	R188-6-HB	$\phi$ .145	NOTE 1	X	X
01761	R188-6-THB	$\phi$ .145	NOTE 2	X	X
01765	R188-6-CPS	$\phi$ .145	NOTE 4		
01770	R188-8-HB	$\phi$ .171	NOTE 1	X	X
01780	R188-8-THB	$\phi$ .171	NOTE 2	X	X
01785	R188-8-CPS	$\phi$ .171	NOTE 4		
01786	R188-6-NPS	$\phi$ .145	NOTE 3		
01787	R188-8-NPS	$\phi$ .171	NOTE 3		
01793	R188-10-HB	$\phi$ .197	NOTE 1	X	X
01801	R188-10-NPS	$\phi$ .197	NOTE 3		
01804	R188-10-THB	$\phi$ .197	NOTE 2	X	X
01805	R188-10-CPS	$\phi$ .197	NOTE 4		

Rev.	Description of Change/ SCN#	Date
1	SCN# 102103 SCJ ORG.ENG.DWG.DATE: 11-13-91	1-14-03
2	R188-10-NPS ADDED COR	4/16/06
3	ADDED P/Cs SCN#140162 SCJ	8-21-07
4	COMPLETED P/C LIST SCJ	7-23-08

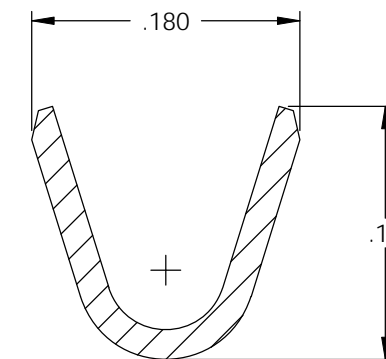

SECTION B-B  
SCALE 8 : 1

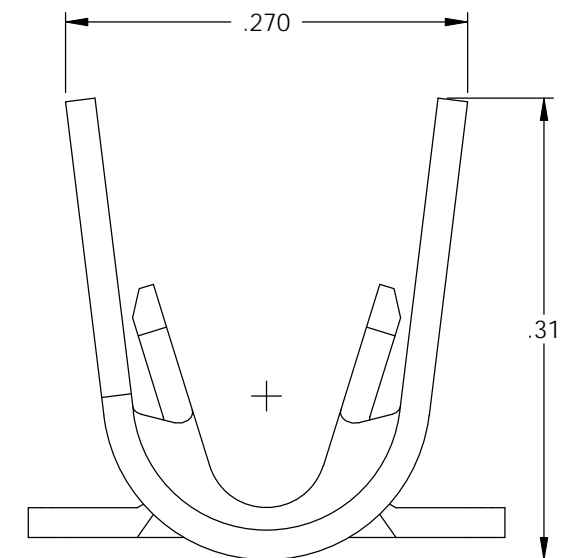

## UNCONTROLLED COPY

<p>THIRD ANGLE PROJECTION TOLERANCES UNLESS OTHERWISE SPECIFIED INCHES: .XX - <math>\pm</math>.030 .XXX - <math>\pm</math>.015 ANGLES: <math>\pm</math>5°</p>	TOOL NO. <b>0029</b>	Title: <b>RING TERMINAL</b>		
	<p>ETCO Incorporated Engineered Products 25 Bellows Street Warwick, RI 02888 Phone: (401) 467-2400 Fax: (401) 467-9230 www.ETCO.com</p>	DO NOT SCALE DWG.	Drawn By: S.JOHNSON	Date: 12-16-02
Chk'd/App'd By:		Scale: 8X	Size: B	Dwg. No.: <b>R188 cust</b>