

NOTES:

- MATERIAL: .020 THICK BRASS
#2 TEMPER (1/2 HARD)
PER ETCO METAL CODE XXXXX.
- MATERIAL: .020 THICK PRETINNED BRASS
#2 TEMPER (1/2 HARD)
PER ETCO METAL CODE 2-1451.
- PARTS MAY BE COATED WITH A LIGHT FILM OF LUBRICATION USED IN THE MANUFACTURING PROCESS.
- WIRE RANGE: 14-20 AWG.

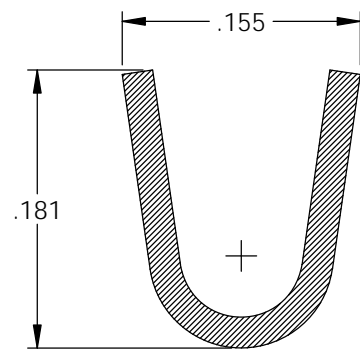

SECTION A-A

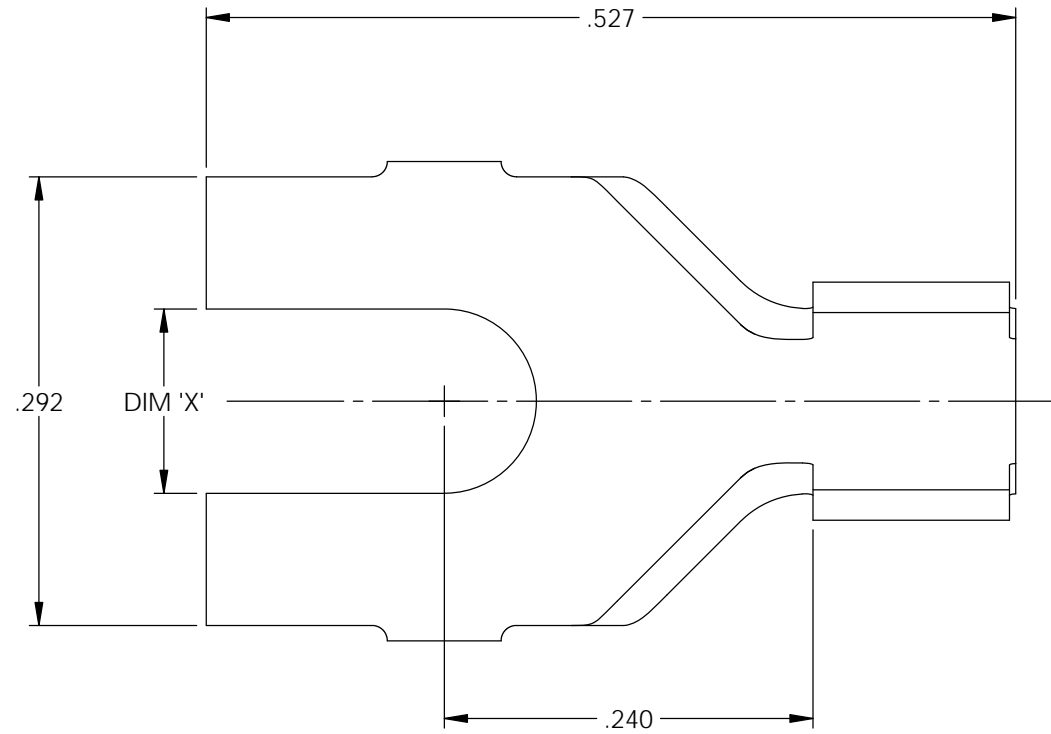
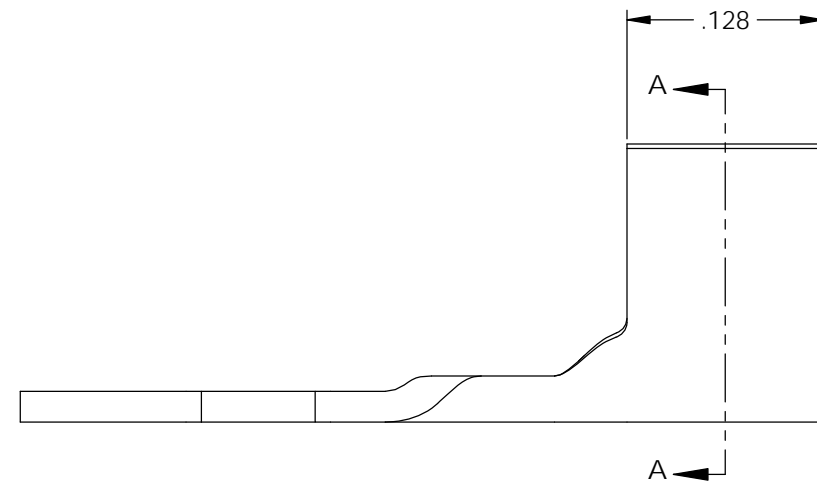

Part Number	Dim 'X'	Mat'l	UL
4000-3A1-3	∅.120	Note 1	X
4000-3A2-3	∅.120	Note 2	X
4000-3A1-5	∅.148	Note 1	X
4000-3A2-5	∅.148	Note 2	X
4000-3A1-7	∅.172	Note 1	X
4000-3A2-7	∅.172	Note 2	X
4000-3A1-9	∅.198	Note 1	X
4000-3A2-9	∅.198	Note 2	X

Rev.	Description of Change/ SCN#	Date
A	Approved For Quote SCJ	5/29/20

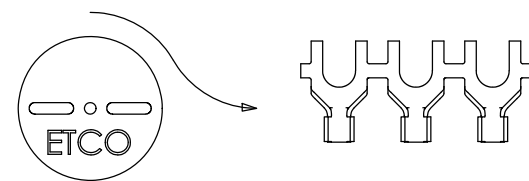
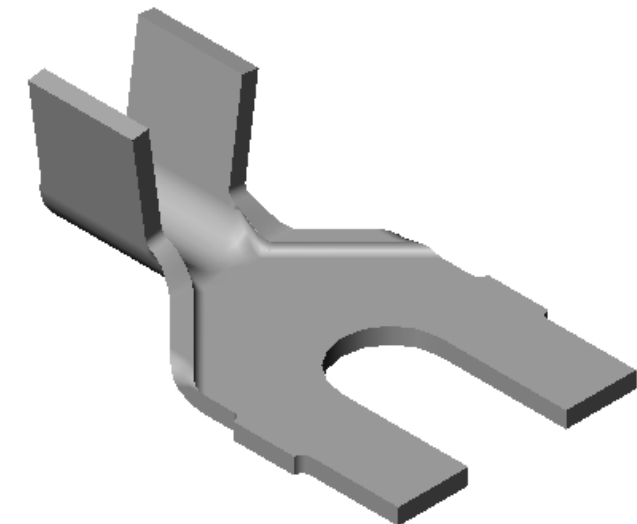

DIRECTION TOWARD APPLICATOR,
EARS UP, TO THE FRONT

UNCONTROLLED COPY

<p>THIRD ANGLE PROJECTION TOLERANCES UNLESS OTHERWISE SPECIFIED INCHES: .XX - ±.030 .XXX - ±.015 ANGLES: ±5°</p>	<p>TOOL NO. 1023</p>	<p>Title: Spade Terminal</p>		
		<p>DO NOT SCALE DWG.</p>	<p>Drawn By: S.Johnson</p>	<p>Date: 5/29/20</p>
<p>ETCO Incorporated Engineered Products 25 Bellows Street Warwick, RI 02888 Phone: (401) 467-2400 Fax: (401) 467-9230 www.ETCO.com</p>		<p>Design Control By: ETCO</p>	<p>Scale: 8X</p>	<p>Size B</p>
		<p>Dwg. No.: 4000 3A1,2 -3,-5,-7,-9 cust</p>		