

NOTES:

- MATERIAL: .032 THICK BRASS
#2 TEMPER (1/2 HARD)
PER ETCO METAL CODE XXXXX.
- MATERIAL: .032 THICK PRETINNED BRASS
#2 TEMPER (1/2 HARD)
PER ETCO METAL CODE XXXXX.
- PARTS MAY BE COATED WITH A LIGHT FILM OF LUBRICATION USED IN THE MANUFACTURING PROCESS.
- WIRE RANGE: 12-20 AWG.

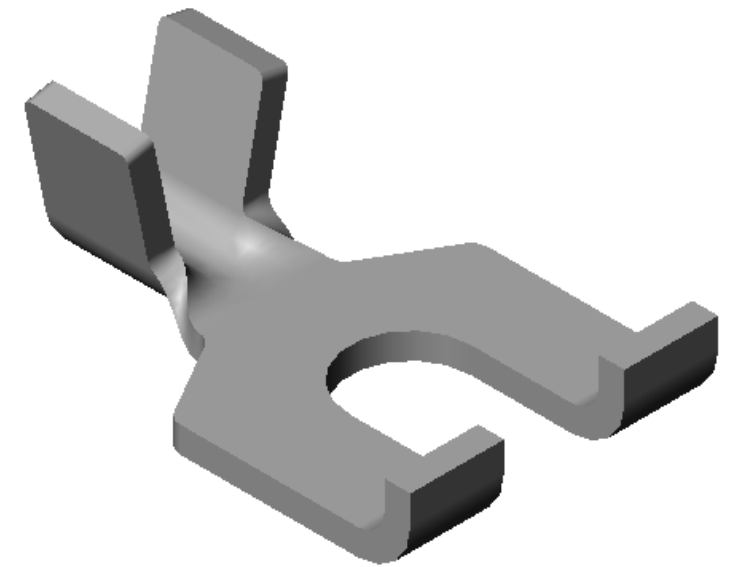
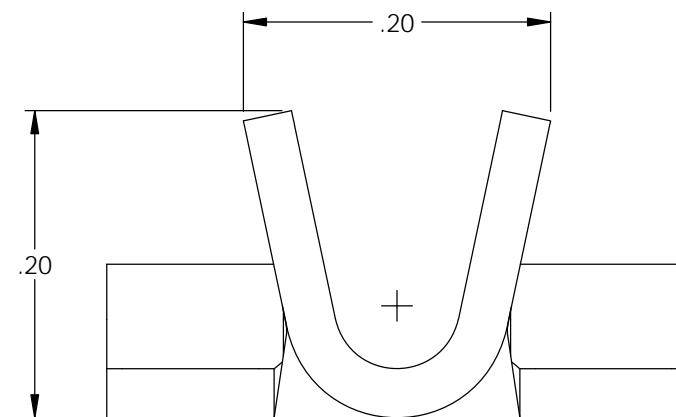
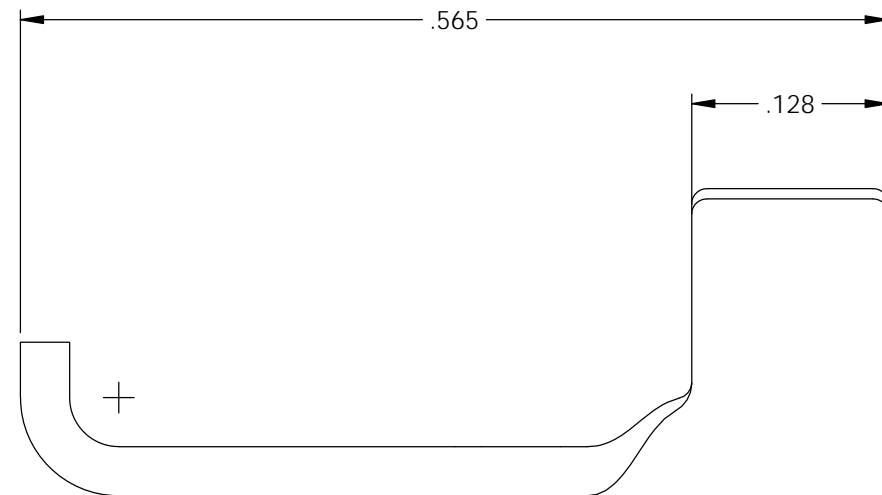
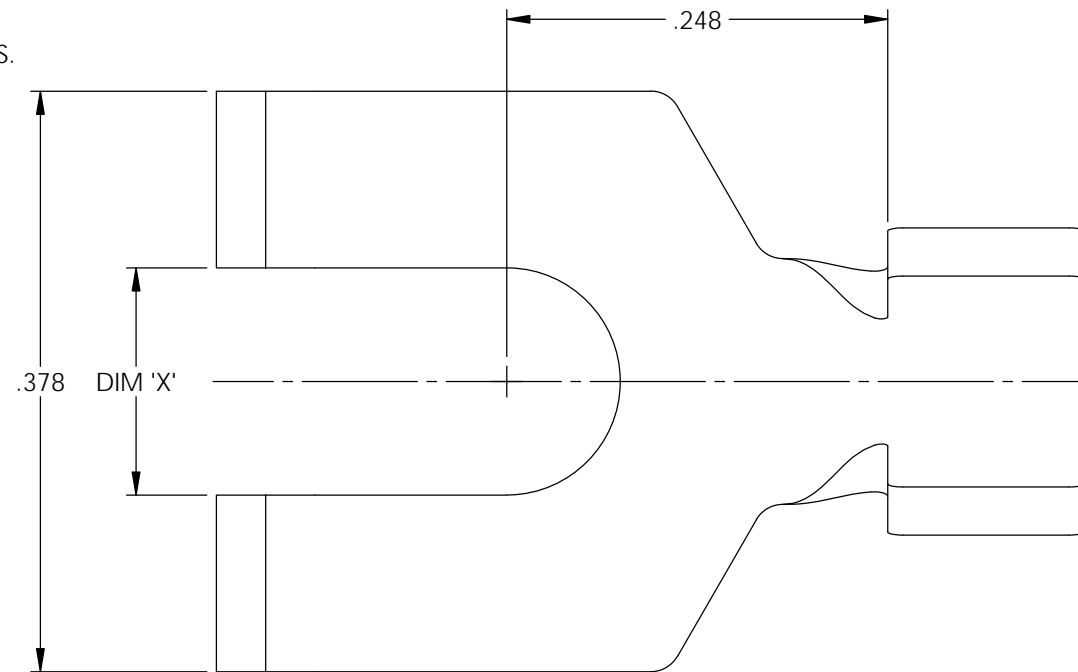

Part Number	DIM 'X'	Mat'l	UL
4000 4B3-5	.148	Note 1	X
4000 4B4-5	.148	Note 2	X
4000 4B3-7	.174	Note 1	X
4000 4B4-7	.174	Note 2	X
4000 4B3-9	.204	Note 1	X
4000 4B4-9	.204	Note 2	X

Rev.	Description of Change/ SCN#	Date
A	Approved For Quote SCJ	6/05/20

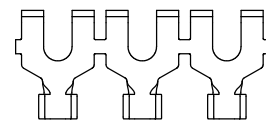
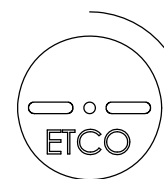

DIRECTION TOWARD APPLICATOR,
EARS UP, TO THE FRONT

THIS PRINT IS THE PROPERTY OF ETCO INCORPORATED. NO PART OF THIS DESIGN MAY BE USED IN ANY WAY WITHOUT WRITTEN CONSENT FROM ETCO INCORPORATED.

UNCONTROLLED COPY

<p>THIRD ANGLE PROJECTION TOLERANCES UNLESS OTHERWISE SPECIFIED INCHES: .XX - ±.030 .XXX - ±.015 ANGLES: ±5°</p>	<p>TOOL NO. 1024</p>	<p>Title: Spade Terminal</p>		
		<p>DO NOT SCALE DWG.</p>	<p>Drawn By: S.Johnson</p>	<p>Date: 4/06/20</p>
<p>ETCO Incorporated Engineered Products 25 Bellows Street Warwick, RI 02888 Phone: (401) 467-2400 Fax: (401) 467-9230 www.ETCO.com</p>		<p>Design Control By: ETCO</p>	<p>Scale: 8X</p>	<p>Size B</p>
<p>Dwg. No.: 4000 4B3 and 4B4-5, -7, -9 cust</p>				