

NOTES:

1. MATERIAL: .032 THICK BRASS  
#2 TEMPER (1/2 HARD)  
PER ETCO METAL CODE XXXXX.
2. MATERIAL: .032 THICK PRETINNED BRASS  
#2 TEMPER (1/2 HARD)  
PER ETCO METAL CODE XXXXX.
3. PARTS MAY BE COATED WITH A LIGHT FILM OF LUBRICATION USED IN THE MANUFACTURING PROCESS.
4. WIRE RANGE: 12-20 AWG.

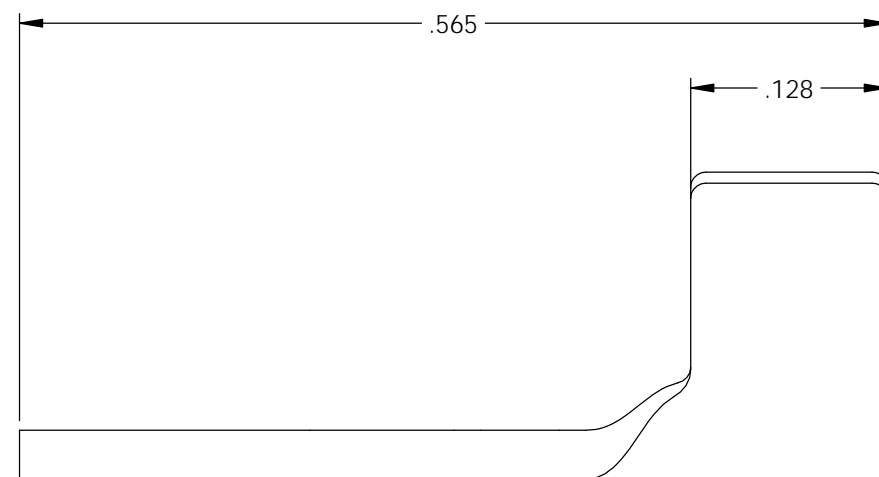
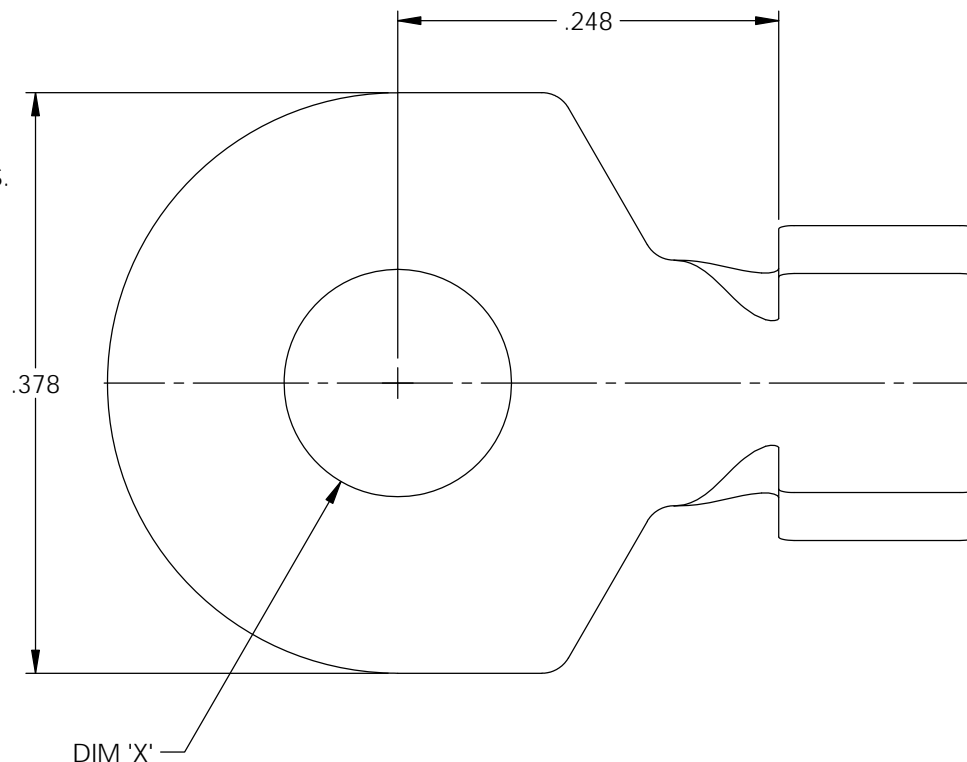

Part Number	DIM 'X'	Mat'l
4000 4G3-5A	.098	Note 1
4000 4G4-5A	.098	Note 2
4000 4G3-7A	.112	Note 1
4000 4G4-7A	.112	Note 2

Rev.	Description of Change/ SCN#	Date
A	Approved For Quote SCJ	6/08/20

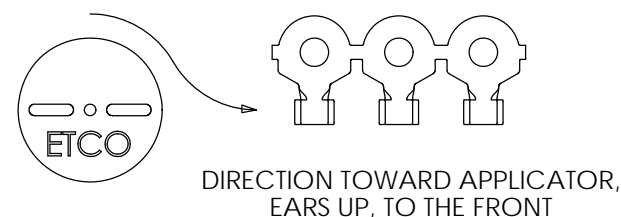
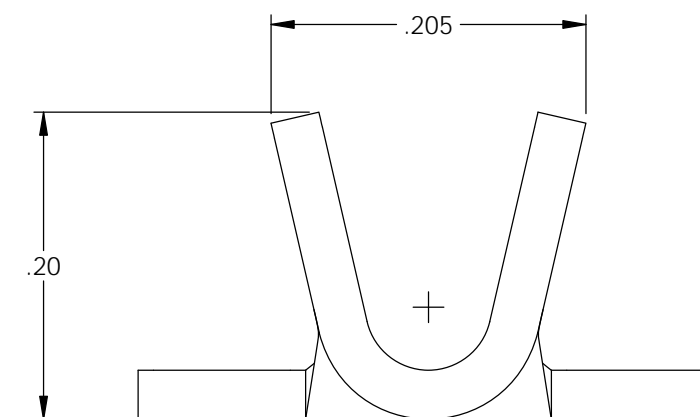
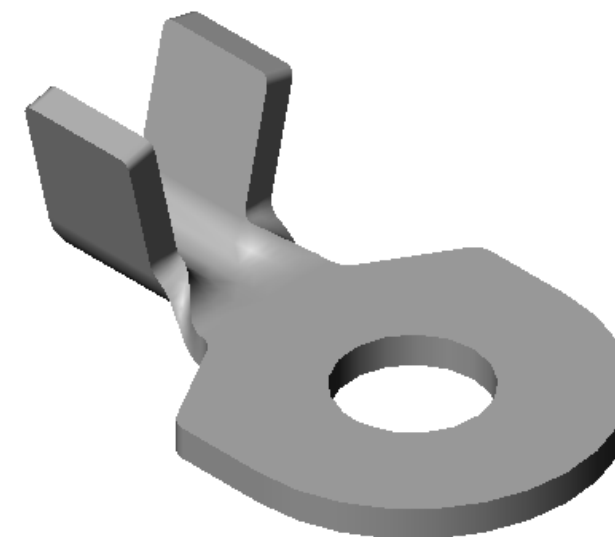

# UNCONTROLLED COPY

<p>THIRD ANGLE PROJECTION TOLERANCES UNLESS OTHERWISE SPECIFIED INCHES: .XX - ±.030 .XXX - ±.015 ANGLES: ±5°</p>	<p>TOOL NO. <b>1024</b></p>	<p>Title: <b>Spade Terminal</b></p>		
		<p>DO NOT SCALE DWG.</p>	<p>Drawn By: <b>S.Johnson</b></p>	<p>Date: <b>6/08/20</b></p>
<p>ETCO Incorporated Engineered Products 25 Bellows Street Warwick, RI 02888 Phone: (401) 467-2400 Fax: (401) 467-9230 www.ETCO.com</p>		<p>Design Control By: <b>ETCO</b></p>	<p>Scale: <b>8X</b></p>	<p>Size <b>B</b></p>
		<p>Dwg. No.: <b>4000 4G3 and 4G4-5A, -7A cust</b></p>		