



**REFERENCE LIST:  
DF70, DF72, DF74  
ECC APPLICATOR  
REAR FEED  
BILL OF MATERIAL NUMBER  
79764**

**WARNING !  
NEVER OPERATE  
THIS OR ANY  
APPLICATOR  
WITHOUT SAFETY  
GUARD IN POSITION.**

PART CODE	PART NUMBER	QUANTITY	DESCRIPTION
77919	1102-FS-1	(1)	PLUNGER
77918	1102-FS	(1)	FLOATING SHANK
71778	*12-DF30	(1)	CUT-OFF PUNCH
72602	*13-D60	(1)	WIRE ROLLING TOOL
73316	13S-DF30	(1)	CUT-OFF SPACER
75713	11B1	(1)	CAM ROLLER BRACKET
75719	1142	(1)	CAM ROLLER BEARING
74422	314L-9A	(1)	CAM BODY
74404	312	(1)	CAM TAPER PIN
74402	310	(1)	CLOCK SPRING
74403	311	(1)	ROLL PIN
76969	169	(1)	UNIVERSAL GIBS - SET OF 2
73903	101-35	(1)	TOP CASTING
73309	408-825	(1)	BRAKE SPACER
74676	407	(1)	SPRING
74675	406	(1)	COTTER PIN
74674	405	(1)	TAPER PIN
74673	404	(1)	BRAKE CAM
74568	403-68	(1)	BRAKE BODY
74496	402	(1)	BRAKE SPRING RETAINER
74495	401	(1)	BRAKE SHAFT
74396	306	(1)	FEED FINGER STOP
74393	305	(1)	FEED FINGER ARM
76894	304-500	(1)	REAR SPACER
74400	308	(1)	FEED SHAFT
76860	307-8	(1)	SPRING
73307	7A-DF30	(1)	FEED FINGER
76873	301-4	(1)	SHOULDER SCREW
76774	500-310	(1)	RIGHT GUIDE
71545	10L-DF30	(1)	LEFT GUIDE
70310	8A-DF30-1	(1)	DIE PLATE
70952	*9-064	(1)	ANVIL
70420	*8B-DF30	(1)	FRONT DIE
70187	*8-068	(1)	REAR DIE
73935	202	(1)	BASE PLATE
76984	177-1	(1)	GUARD
77602	176S-060	(2)	GUARD SPACER

**NOTE: ITEMS MARKED WITH AN \*  
ARE HIGH WEAR ITEMS**



**REFERENCE LIST:  
DF70, DF72, DF74  
ECC APPLICATOR  
REAR FEED  
BILL OF MATERIAL NUMBER  
79764**

**WARNING !  
NEVER OPERATE  
THIS OR ANY  
APPLICATOR  
WITHOUT SAFETY  
GUARD IN POSITION.**

PART CODE	PART NUMBER	QUANTITY	DESCRIPTION
		(11)	8-32 X 3/8" S.H.C.S.
		(2)	8-32 X 1/2" S.H.C.S.
		(2)	8-32 X 5/8" S.H.C.S.
		(2)	10-32 X 3/4" S.H.C.S.
		(1)	10-32 X 5/8" S.H.C.S.
		(1)	10-32 X 1 1/4" S.H.C.S.
		(2)	1/4-20 X 1/4" S.S.S.
		(1)	1/4-28 X 1/2" S.H.C.S.
		(1)	1/4-28 X 3/4" S.S.S.
		(2)	1/4-20 X 1" S.H.C.S.
		(1)	1/4-28 JAM NUT
		(2)	1/8 X 1" DOWEL
		(2)	1/4 X 1" DOWEL
		(1)	5/16 X 3/4" SHOULDER SCREW

**NOTE: ITEMS MARKED WITH AN \*  
ARE HIGH WEAR ITEMS**

*ECC APPLICATOR  
REAR FEED  
DF70, DF72, DF74*

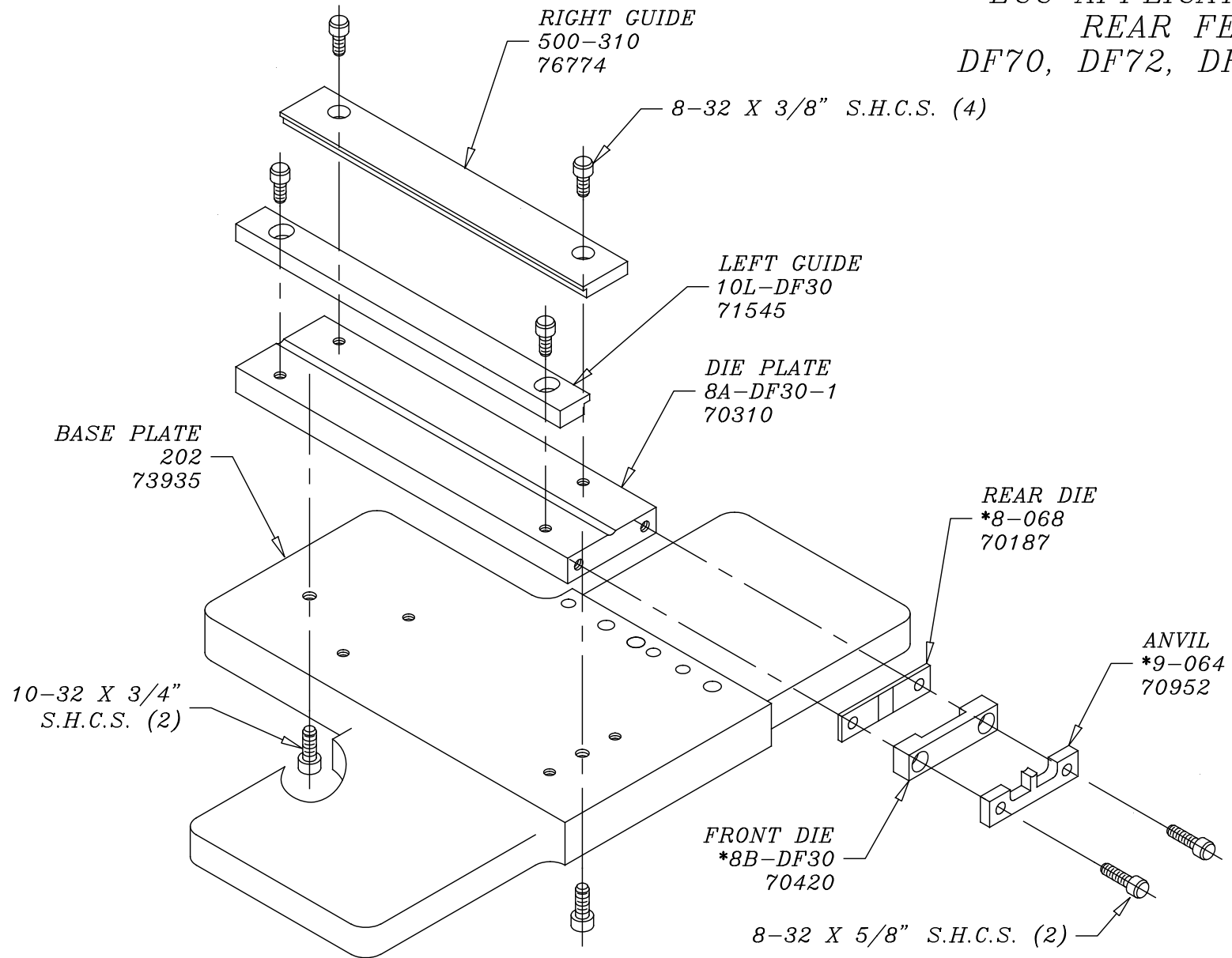

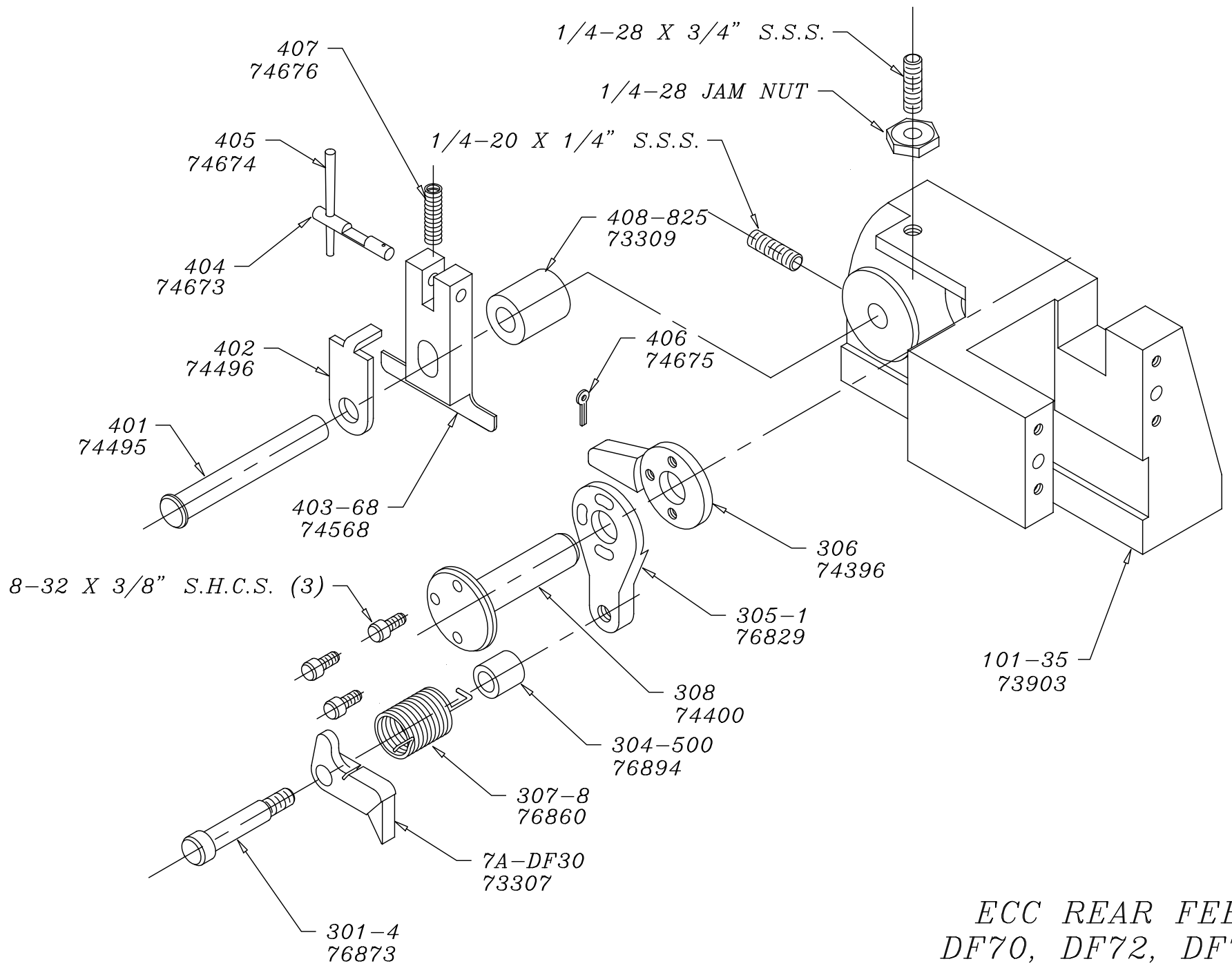

*ECC REAR FEED  
DF70, DF72, DF74*

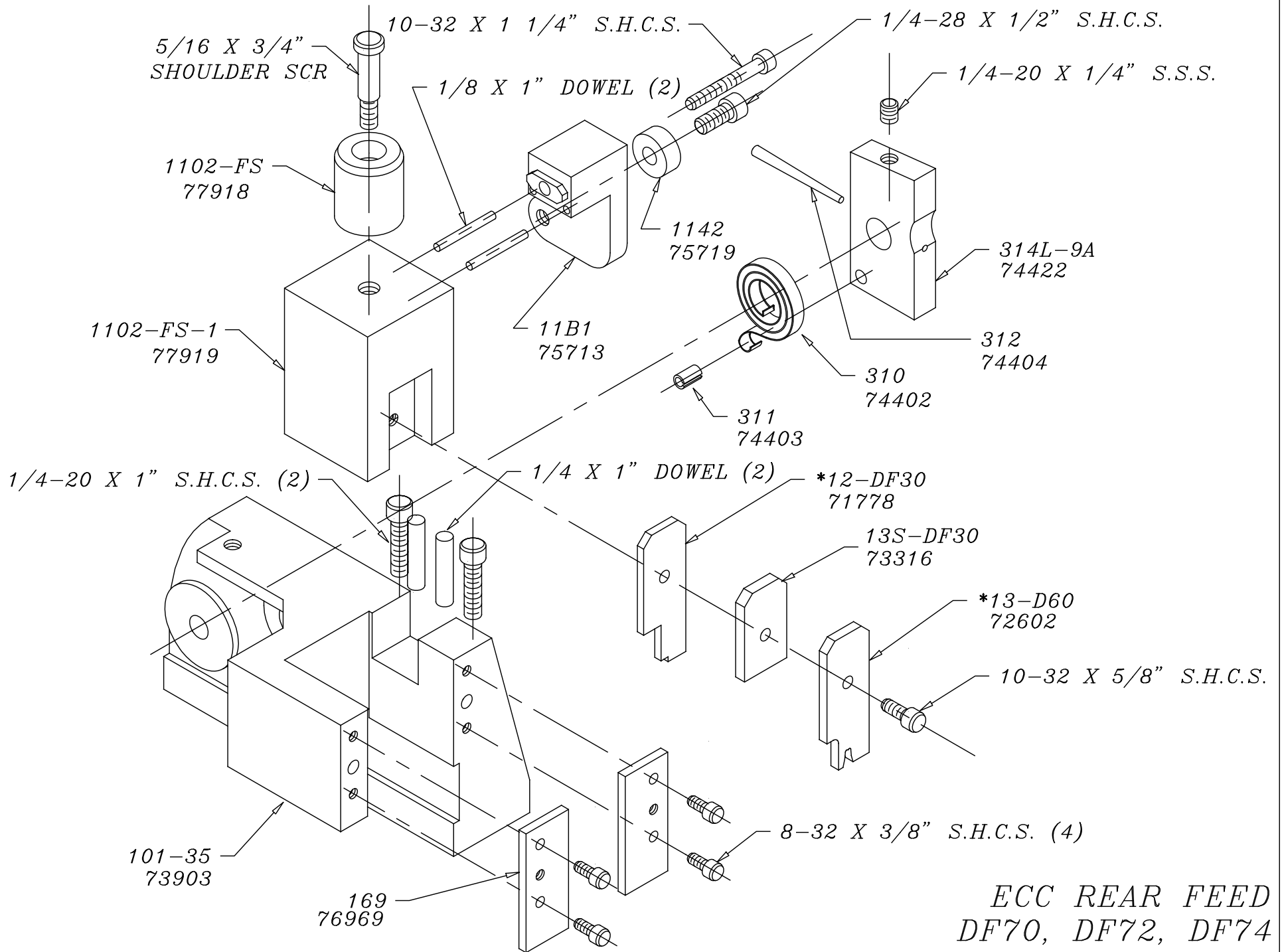

ECC REAR FEED  
 DF70, DF72, DF74

*ECC REAR FEED  
DF70, DF72, DF74*

