

NOTE:

- 1.) MAT'L: .010 THK., BRASS, #4 TEMPER (FULL HARD), PER ETCO METAL CODE NO. 00047.
- 2.) MAT'L: .010 THK., PRE-TINNED BRASS, #4 TEMPER (FULL HARD), PER ETCO METAL CODE NO. 01054.
- 3.) PARTS MAY BE COATED WITH A LIGHT FILM OF LUBRICATION USED IN THE MANUFACTURING PROCESS.
- 4.) FITS UP TO 1,000 CMA.

P/C	DESCRIPTION	MAT'L
10010	A85-10-HB	NOTE 1
10012	A85-10-THB	NOTE 2

Rev.	Description of Change/ SCN#	Date
1	REDRAWN ON SOLIDWORKS NO CHANGES SCJ ORG.ENG.DWG.DATE: 5-14-91	9-22-05

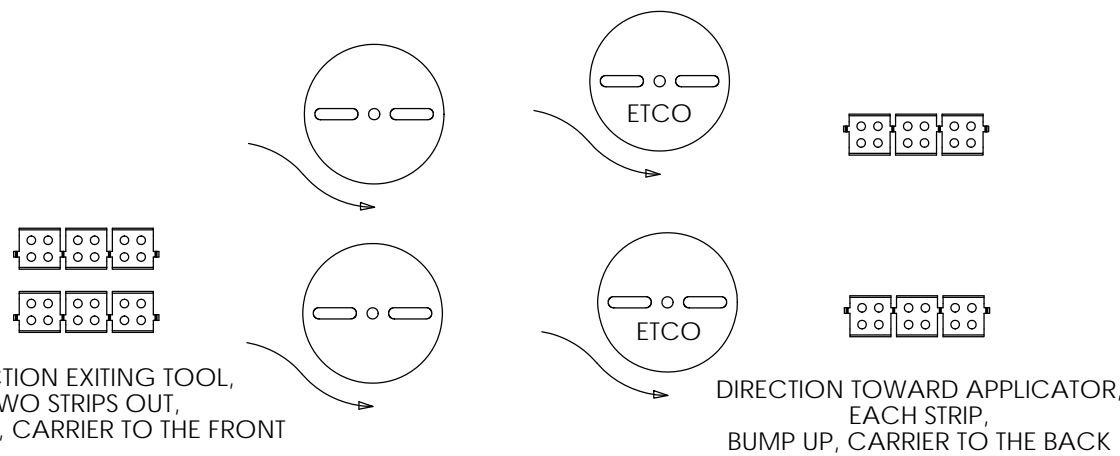
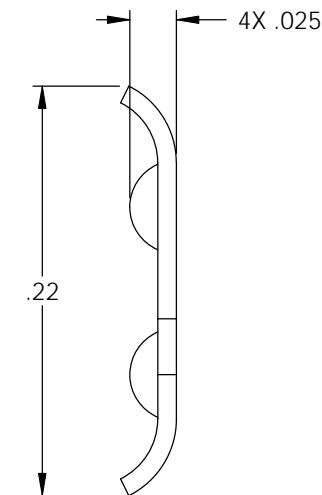
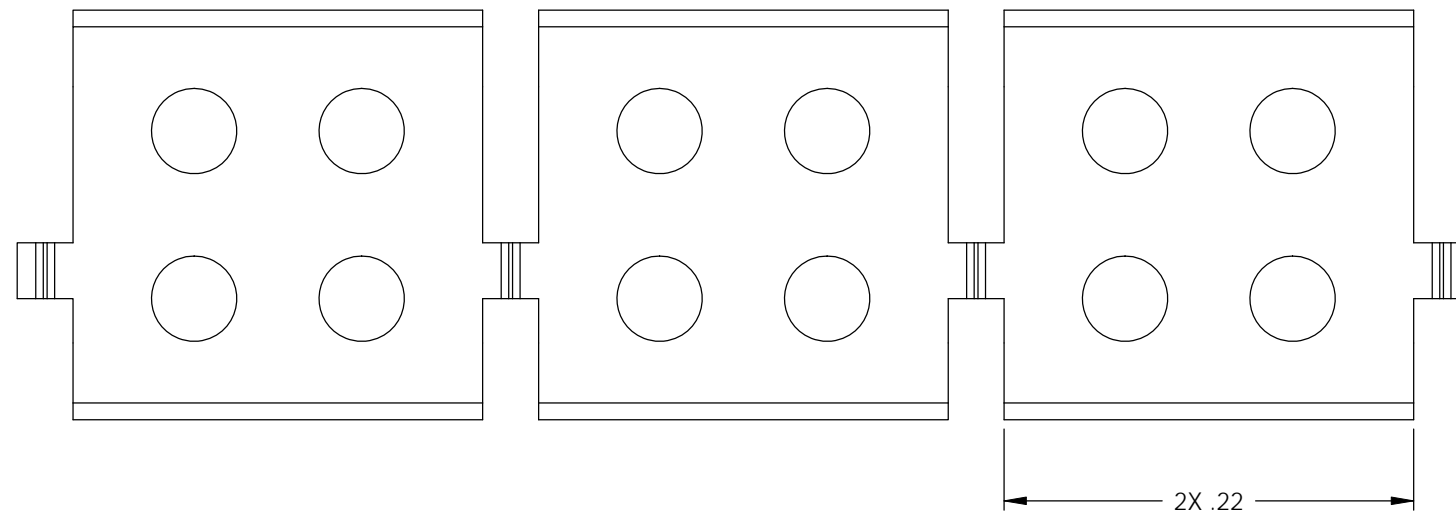
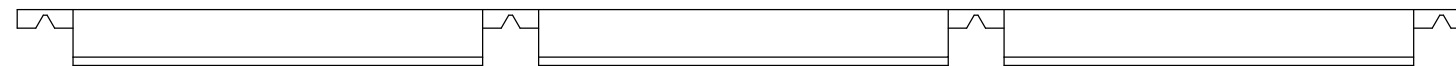
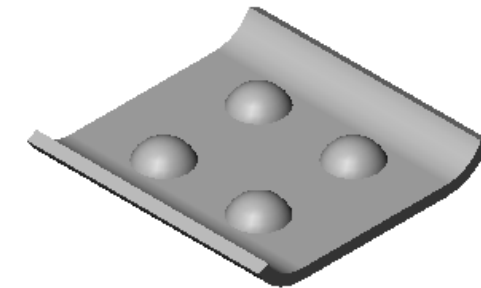

UNCONTROLLED COPY

<p>THIRD ANGLE PROJECTION TOLERANCES UNLESS OTHERWISE SPECIFIED INCHES: .XX - ±.030 .XXX - ±.015 ANGLES: ±5°</p>	<p>TOOL NO. 0662</p>	<p>Title: AUTOBAND</p>		
		<p>DO NOT SCALE DWG.</p>	<p>Drawn By: S.JOHNSON</p>	<p>Date: 9-22-05</p>
<p>ETCO Incorporated Engineered Products 25 Bellows Street Warwick, RI 02888 Phone: (401) 467-2400 Fax: (401) 467-9230 www.ETCO.com</p>		<p>Chk'd/App'd By:</p>	<p>Scale: 10X</p>	<p>Size B</p>
		<p>Dwg. No.: A85-10 cust</p>		