

NOTES:

1. MATERIAL: .010 THICK BRASS
#4 TEMPER (FULL HARD)
PER ETCO METAL CODE 00010.
2. MATERIAL: .010 THICK PRETINNED BRASS
#4 TEMPER (FULL HARD)
PER ETCO METAL CODE 01022.
3. PARTS MAY BE COATED WITH A LIGHT FILM OF LUBRICATION USED IN THE MANUFACTURING PROCESS.
4. INSERTION/WITHDRAWAL FORCES ARE INDICATED ON THE QUALITY INSPECTION PLAN.
5. ACCEPTED MALE: .020 X .110.
6. WIRE RANGE: 26 AWG.

P/C	DESCRIPTION	MAT'L
07205	D55-HB	NOTE 1
07206	D55-THB	NOTE 2

Rev.	Description of Change/ SCN#	Date
-	Approved For Mfg SCJ	2/04/20

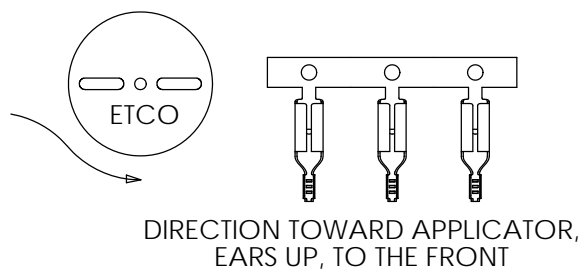
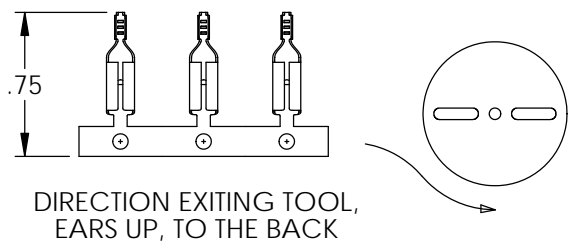
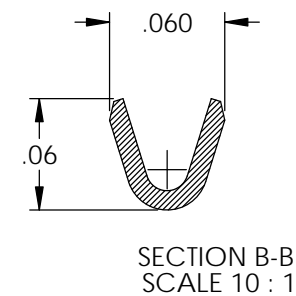
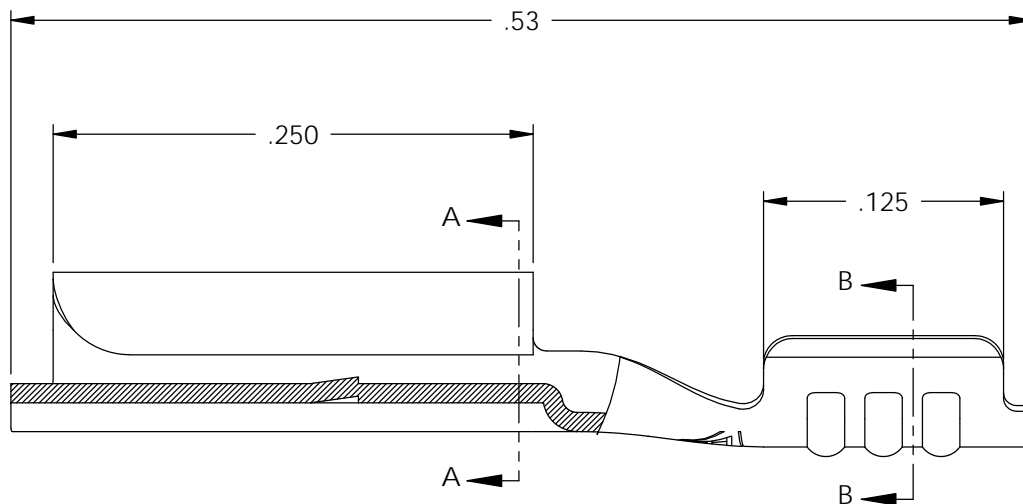
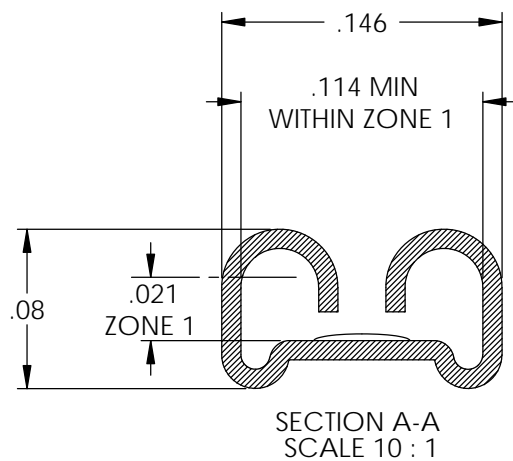
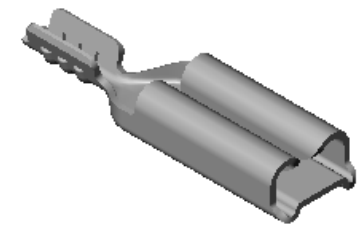
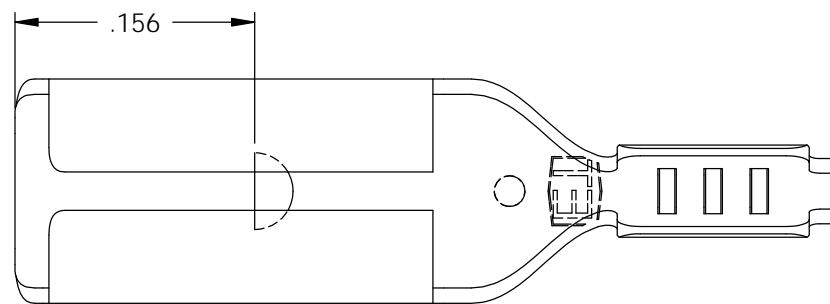

UNCONTROLLED COPY

<p>THIRD ANGLE PROJECTION TOLERANCES UNLESS OTHERWISE SPECIFIED INCHES: .XX - ±.030 .XXX - ±.015 ANGLES: ±5°</p>	<p>TOOL NO. 0096</p>	<p>Title: .020 X .110 FEMALE DISCONNECT</p>		
		<p>DO NOT SCALE DWG.</p>	<p>Drawn By: S.JOHNSON</p>	<p>Date: 9/17/12</p>
<p>ETCO Incorporated Engineered Products 25 Bellows Street Warwick, RI 02888 Phone: (401) 467-2400 Fax: (401) 467-9230 www.ETCO.com</p>		<p>Chk'd/App'd By:</p>	<p>Scale: 10X</p>	<p>Size B</p>
		<p>Dwg. No.: D55 cust</p>		