



- NOTES:
- MATERIAL: .010 THICK BRASS
#4 TEMPER (FULL HARD)
PER ETCO METAL CODE 00018.
 - MATERIAL: .010 THICK PRE-TINNED BRASS
#4 TEMPER (FULL HARD)
PER ETCO METAL CODE 01024.
 - PARTS MAY BE COATED WITH A LIGHT FILM OF LUBRICATION USED IN THE MANUFACTURING PROCESS.
 - INSERTION/WITHDRAWAL FORCES ARE INDICATED ON THE QUALITY INSPECTION PLAN.
 - ACCEPTS A .020 X .110 NEMA STANDARD MALE.
 - WIRE RANGE: 24-18 AWG.
 - INSULATION RANGE: \varnothing .045-.110

P/C	DESCRIPTION	MAT'L		
07272	D62L-HB	NOTE 1	X	X
07273	D62L-THB	NOTE 2	X	X

Rev.	Description of Change/ SCN#	Date
1	SCN# 140299 SCJ ORG.ENG.DWG.DATE: 5-19-80	11-16-07

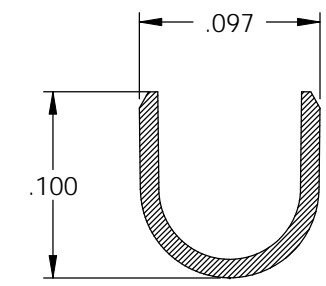
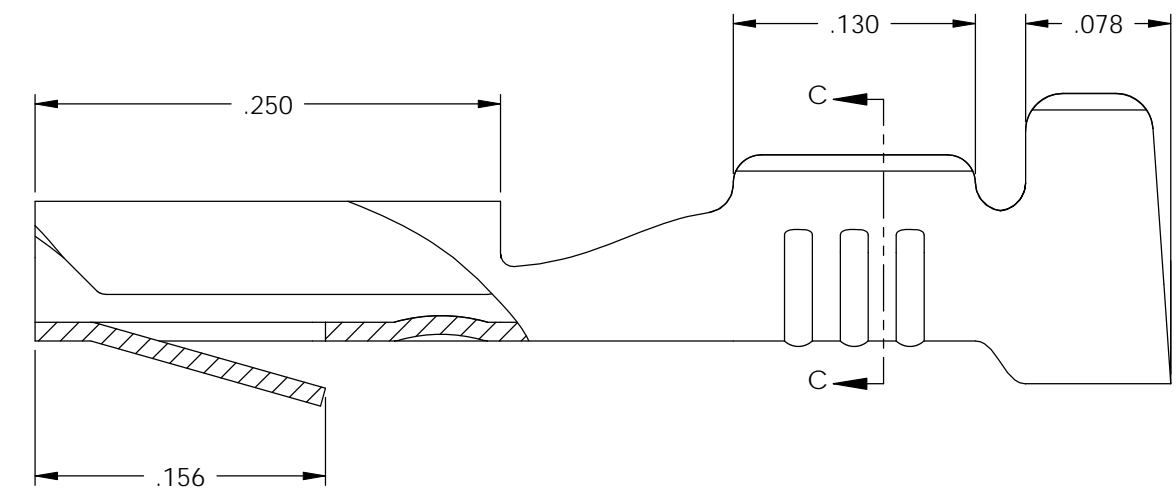
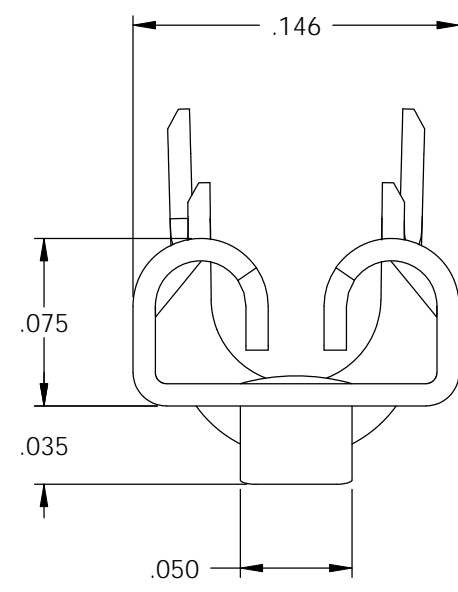
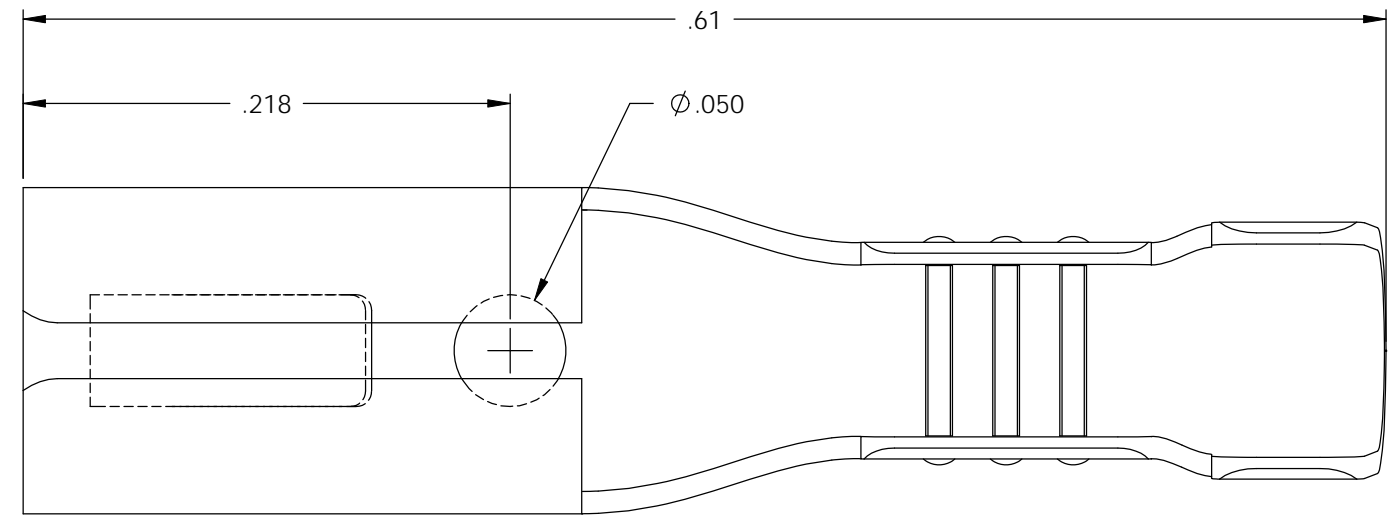
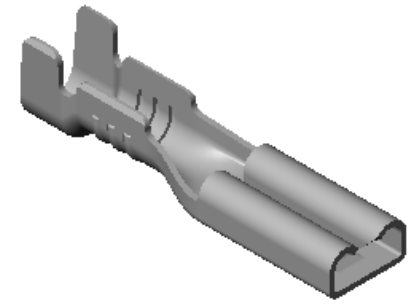

SECTION C-C
SCALE 10 : 1

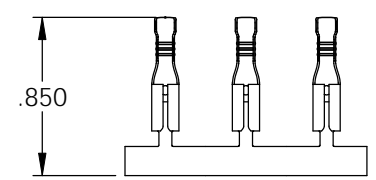
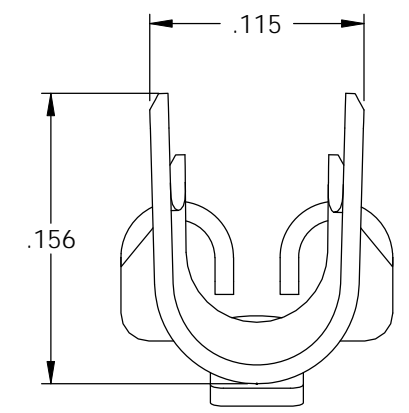

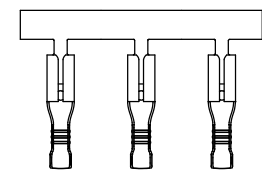
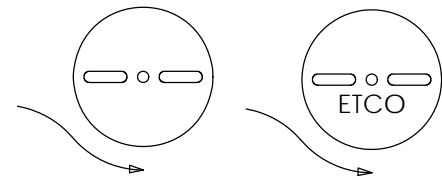

DIRECTION EXITING TOOL,
EARS UP, CARRIER TO THE FRONT



DIRECTION TOWARD APPLICATOR,
EARS UP, CARRIER TO THE BACK

THIS PRINT IS THE PROPERTY OF ETCO INCORPORATED. NO PART OF THIS DESIGN MAY BE USED IN ANY WAY WITHOUT WRITTEN CONSENT FROM ETCO INCORPORATED.

UNCONTROLLED COPY

 THIRD ANGLE PROJECTION TOLERANCES UNLESS OTHERWISE SPECIFIED INCHES: .XX - \pm .030 .XXX - \pm .015 ANGLES: \pm 5°	TOOL NO. 0098	Title: .020 X .110 FEMALE DISCONNECT		
		DO NOT SCALE DWG.	Drawn By: S.JOHNSON	Date: 11-15-07
ETCO Incorporated Engineered Products 25 Bellows Street Warwick, RI 02888 Phone: (401) 467-2400 Fax: (401) 467-9230 www.ETCO.com		Chk'd/App'd By:	Scale: 10X	Size B
		Dwg. No.: D62L cust		