

NOTES:

1. MATERIAL: .032 THICK, BRASS, #2 TEMPER (1/2 HARD) PER ETCO METAL CODE 00840.
2. MATERIAL: .032 THICK, PRE-TINNED BRASS, #2 TEMPER (1/2 HARD) PER ETCO METAL CODE 01840.
3. PARTS MAY BE COATED WITH A LIGHT FILM OF LUBRICATION USED IN THE MANUFACTURING PROCESS.
4. WIRE RANGE: 14 AWG.

P/C	DESCRIPTION	MAT'L
08055	M219-HB	NOTE 1
08056	M219-THB	NOTE 2

Rev.	Description of Change/ SCN#	Date
2	REDRAWN ON SOLIDWORKS NO CHANGES ORG.ENG.DWG.DATE: 12-18-84	11-21-07

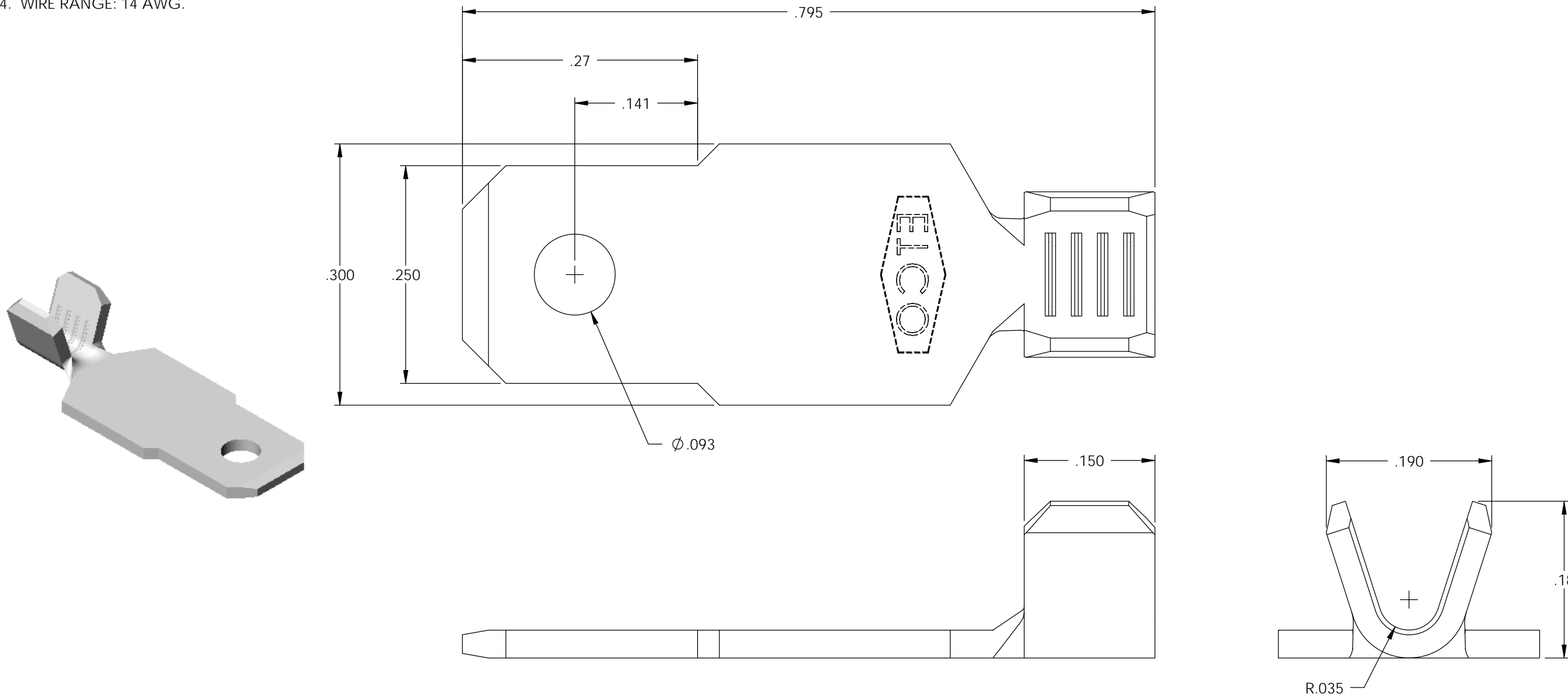

# UNCONTROLLED COPY

<p>THIRD ANGLE PROJECTION TOLERANCES UNLESS OTHERWISE SPECIFIED INCHES: .XX - ±.030 .XXX - ±.015 ANGLES: ±5°</p>	<p>TOOL NO. <b>0635</b></p>	<p>Title: .032 X .250 MALE DISCONNECT</p>		
		<p>DO NOT SCALE DWG.</p>	<p>Drawn By: S.JOHNSON</p>	<p>Date: 11-21-07</p>
<p>ETCO Incorporated Engineered Products 25 Bellows Street Warwick, RI 02888 Phone: (401) 467-2400 Fax: (401) 467-9230 www.ETCO.com</p>		<p>Chk'd/App'd By:</p>	<p>Scale: 8X</p>	<p>Size B</p>
		<p>Dwg. No.: <b>M219 cust</b></p>		

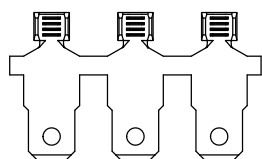

DIRECTION EXITING TOOL,  
EARS UP, TO THE BACK

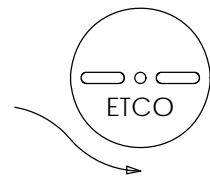
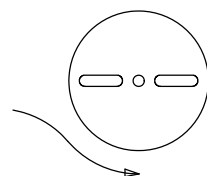

M219  
DIRECTION TOWARD APPLICATOR,  
EARS UP, TO THE FRONT