

- NOTE:
- 1.) MAT'L: .040 THK., BRASS, #2 TEMPER (HALF HARD), PER ETCO METAL CODE NO. 00990.
 - 2.) MAT'L: .040 THK., PRE-TINNED BRASS, #2 TEMPER (HALF HARD), PER ETCO METAL CODE NO. 01822.
 - 3.) PARTS MAY BE COATED WITH A LIGHT FILM OF LUBRICATION USED IN THE MANUFACTURING PROCESS.
 - 4.) WIRE RANGE: 10-8 AWG.

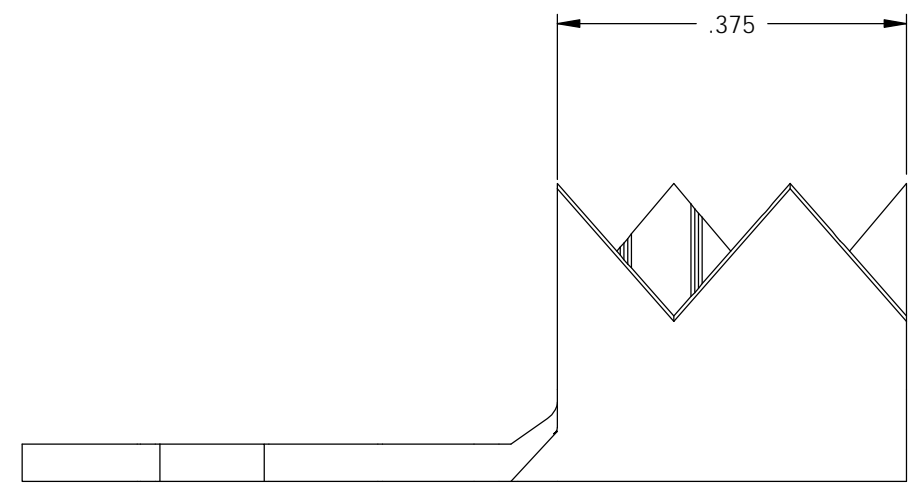

P/C	DESCRIPTION	DIM 'X'	MAT'L
02424	R433-244-HB	Ø.244	NOTE 1

Rev.	Description of Change/ SCN#	Date
A	APPROVED FOR TOOLING SCJ	9-13-06

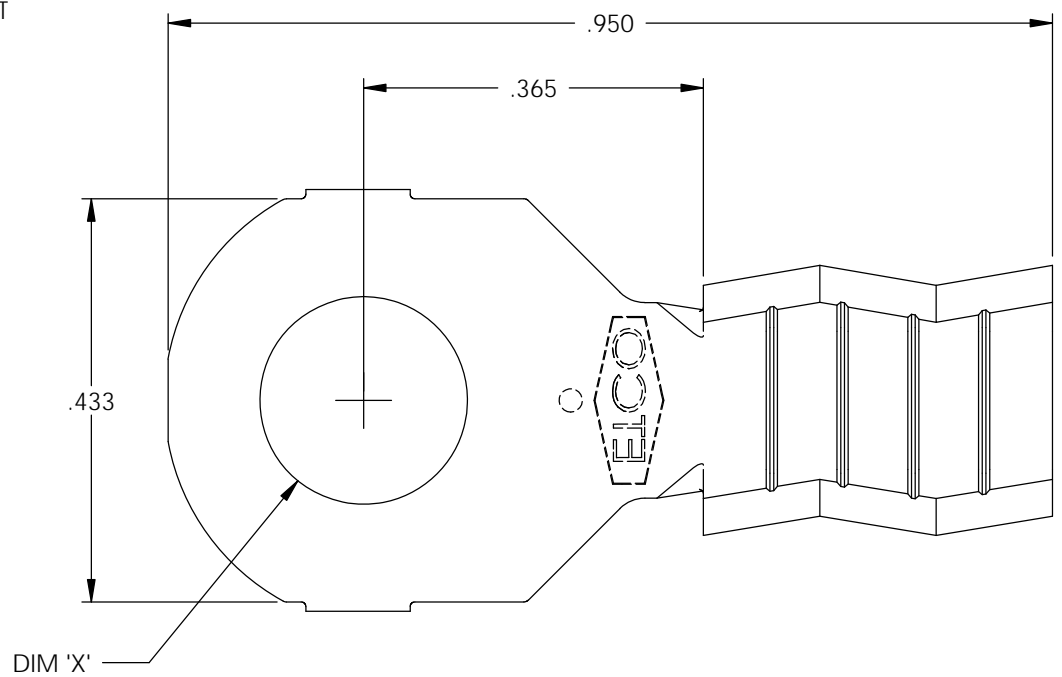
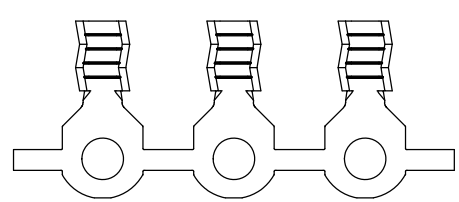
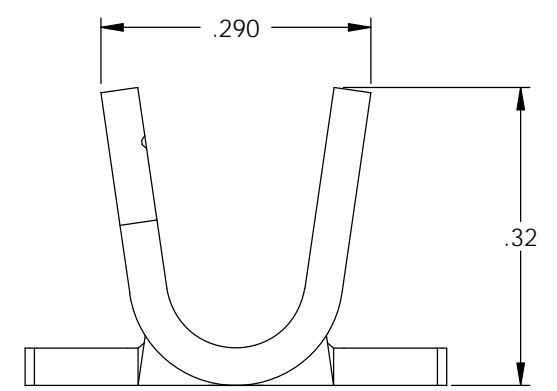
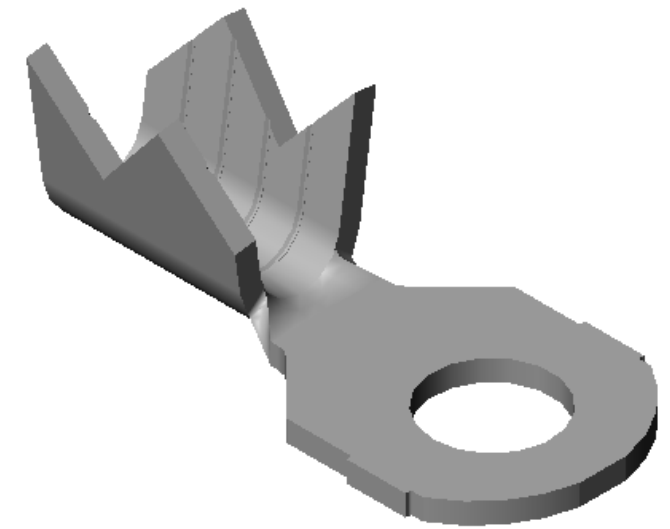

DIRECTION EXITING TOOL, EARS UP, TO THE BACK

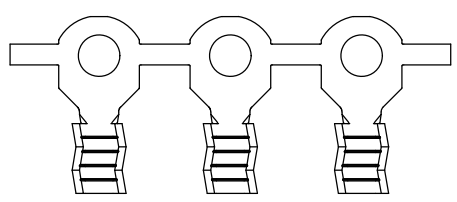
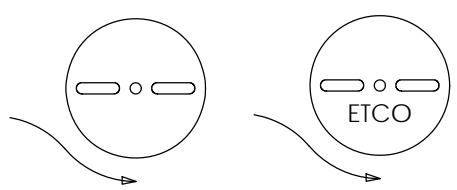

DIRECTION TOWARD APPLICATOR, EARS UP, TO THE FRONT

THIS PRINT IS THE PROPERTY OF ETCO INCORPORATED. NO PART OF THIS DESIGN MAY BE USED IN ANY WAY WITHOUT WRITTEN CONSENT FROM ETCO INCORPORATED.

UNCONTROLLED COPY

<p>THIRD ANGLE PROJECTION TOLERANCES UNLESS OTHERWISE SPECIFIED INCHES: .XX - ±.030 .XXX - ±.015 ANGLES: ±5°</p>	<p>TOOL NO. 0047</p>	<p>Title: RING TERMINAL</p>		
		<p>DO NOT SCALE DWG.</p>	<p>Drawn By: S. JOHNSON</p>	<p>Date: 9-13-06</p>
<p>ETCO Incorporated Engineered Products 25 Bellows Street Warwick, RI 02888 Phone: (401) 467-2400 Fax: (401) 467-9230 www.ETCO.com</p>		<p>Chk'd/App'd By:</p>	<p>Scale: 5X</p>	<p>Size B</p>
		<p>Dwg. No.: R433 cust</p>		