

NOTE:

- MAT'L: .018 THK. PRE-TINNED BRASS, #4 TEMPER (FULL HARD), PER ETCO METAL CODE NO. 02462.
- PARTS MAY BE COATED WITH A LIGHT FILM OF LUBRICATION USED IN THE MANUFACTURING PROCESS.
- PART SHOWN: REC90-40-TRL

P/C	DESCRIPTION	WIRE RANGE	INSUL RANGE	DIM 'A'	DIM 'B'	DIM 'D'	DIM 'E'	REWIND
09426	REC90-40-TRL	TWO 18 AWGs OR TWO 20 AWGs	∅.105-.150	.160	.145	.230	.165	NO
09427	REC90-50-TRL	TWO 16 AWGs OR 20-14 AWG	∅.120-170	.180	.175	.260	.195	NO
09429	REC90-40R-TRL	TWO 18 AWGs OR TWO 20 AWGs	∅.105-150	.160	.145	.230	.165	YES

Rev.	Description of Change/ SCN#	Date

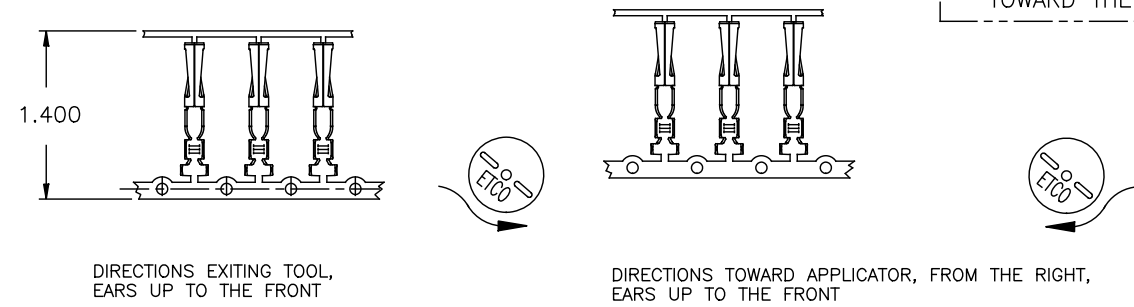
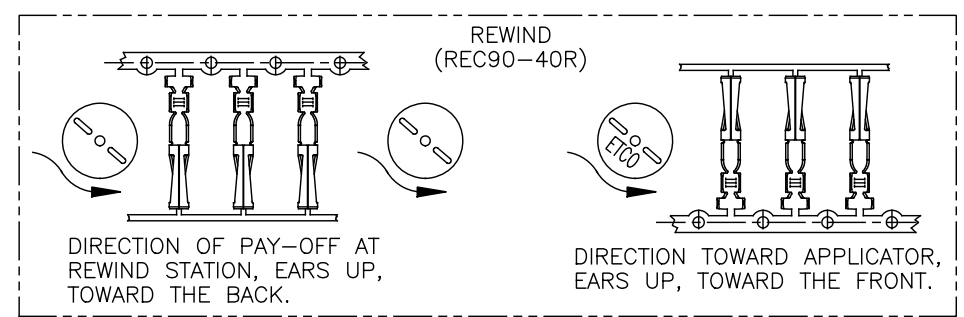
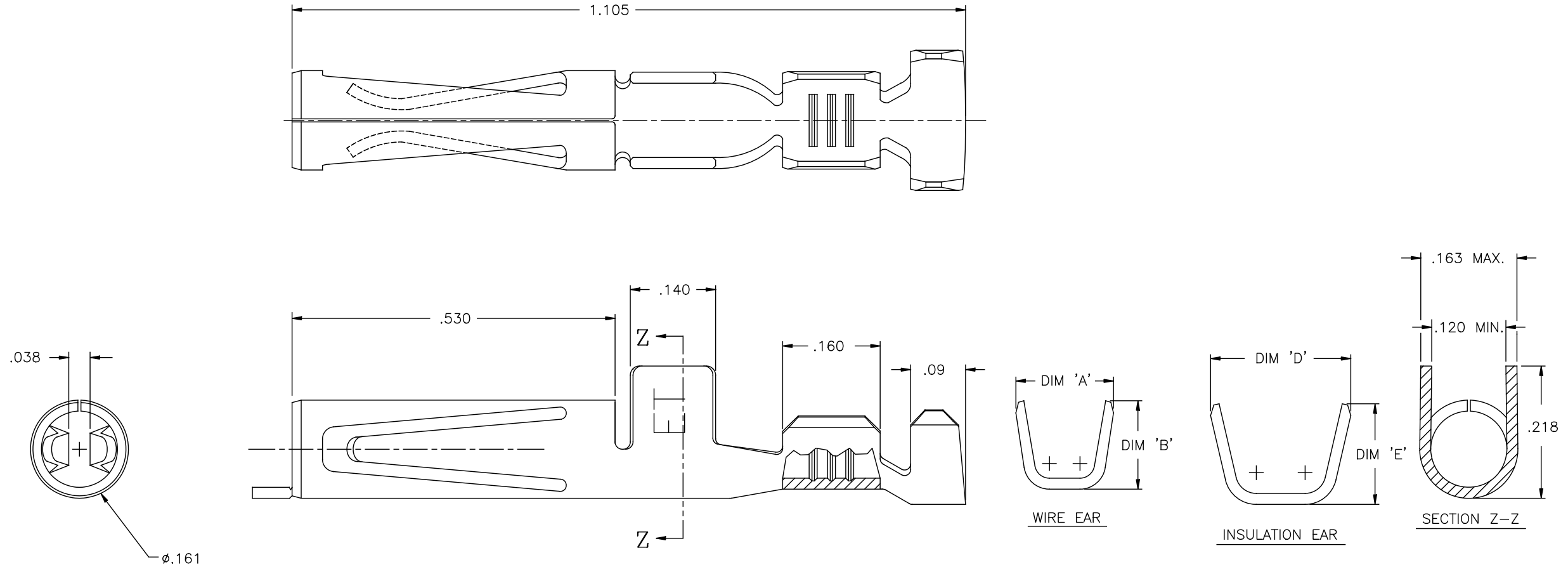

**UNCONTROLLED COPY**

<p>THIRD ANGLE PROJECTION TOLERANCES UNLESS OTHERWISE SPECIFIED .XX - ±.030 .XXX - ±.015 Angles - ±2°</p>	TOOL NO. <b>0468</b>	Title: RECEPTACLE	
		DO NOT SCALE DWG.	Drawn By: P. McCormick Checked: [ ] Dwg. No.: C- REC90-40/-50
Date: 1-15-97		Scale: 8:1 Size: C	

ETCO Incorporated  
Engineered Products  
25 Bellows Street  
Warwick, R.I. 02888  
Phone: (401)467-2400  
FAX: (401)467-9230