

NOTE:

- 1.) MAT'L: .020 THK., BRASS, #2 TEMPER (HALF HARD), PER ETCO METAL CODE NO. 00280.
- 2.) MAT'L: .020 THK., PRE-TINNED BRASS, #2 TEMPER (HALF HARD), PER ETCO METAL CODE NO. 01350.
- 3.) MAT'L: .020 THK., PRE-NICKEL PLATED STEEL, #3 TEMPER (QUARTER HARD), PER ETCO METAL CODE NO. 03205.
- 4.) PARTS MAY BE COATED WITH A LIGHT FILM OF LUBRICATION USED IN THE MANUFACTURING PROCESS.
- 5.) WIRE RANGE: 18-16 AWG.

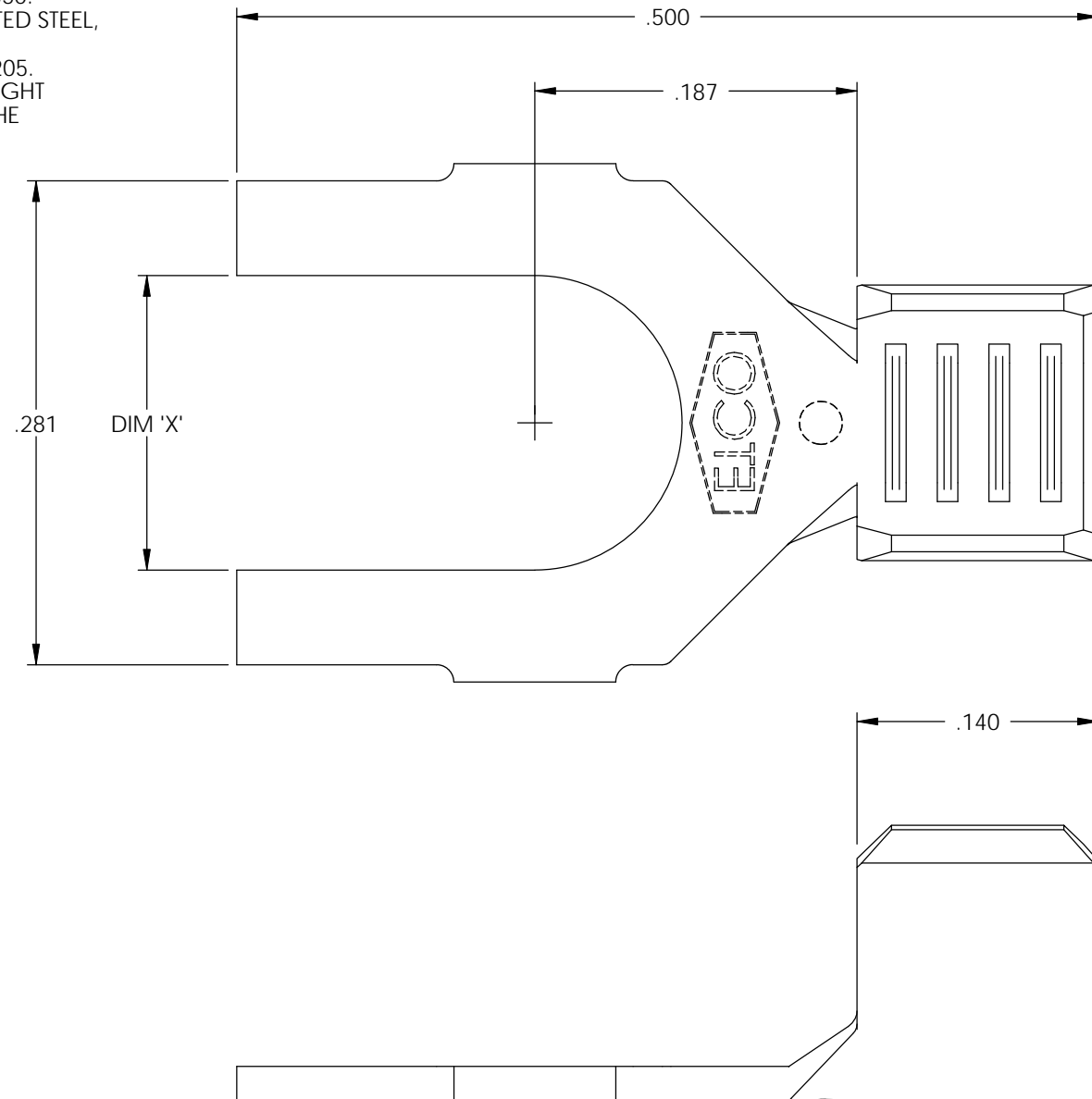

P/C	DESCRIPTION	DIM 'X'	MAT'L	UL
03098	S112N-6-NPS	.145	NOTE 3	
03107	S112N-4-HB	.119	NOTE 1	X
03108	S112N-4-THB	.119	NOTE 2	X
03109	S112N-4-NPS	.119	NOTE 3	
03111	S112N-6-HB	.145	NOTE 1	X
03112	S112N-6-THB	.145	NOTE 2	X
03113	S112N-8-HB	.171	NOTE 1	X
03114	S112N-8-THB	.171	NOTE 2	X
03115	S112N-8-NPS	.171	NOTE 3	

Rev.	Description of Change/ SCN#	Date
1	SCN# 102057 SCJ ORG.ENG.DWG.DATE: 1-13-93	11-18-02
2	ADDED P/Cs SCN#140162 SCJ	7-31-07

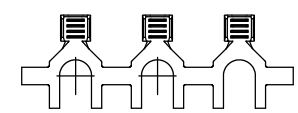
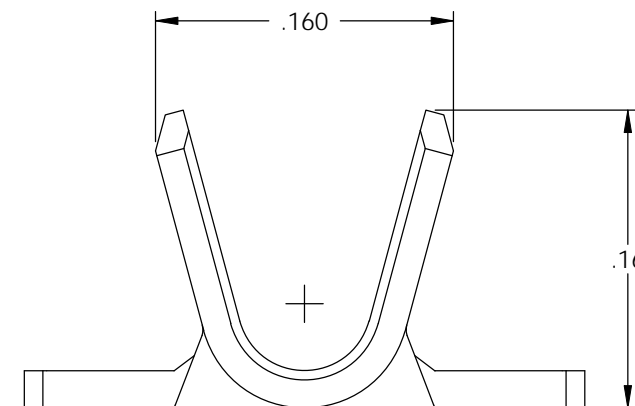
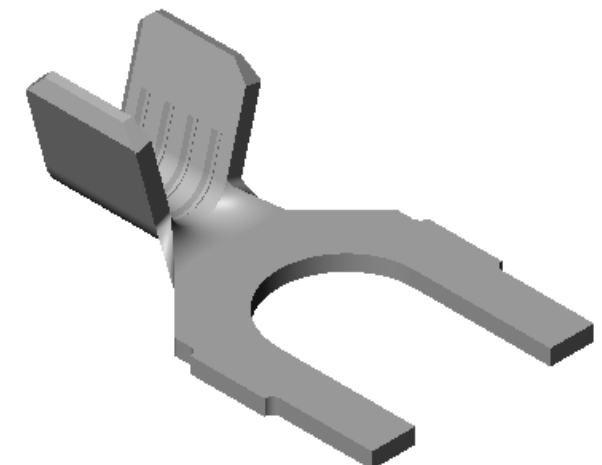

DIRECTION EXITING TOOL,  
EARS UP TO THE BACK

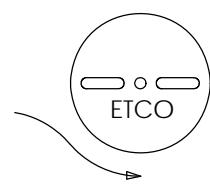
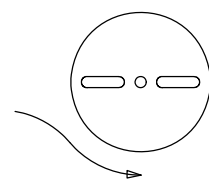

DIRECTION TOWARD APPLICATOR,  
EARS UP TO THE FRONT

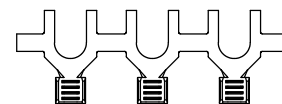

# UNCONTROLLED COPY

<p>THIRD ANGLE PROJECTION TOLERANCES UNLESS OTHERWISE SPECIFIED INCHES: .XX - ±.030 .XXX - ±.015 ANGLES: ±5°</p>	<p>TOOL NO. <b>0675</b></p>	<p>Title: <b>SPADE TERMINAL</b></p>		
		<p>DO NOT SCALE DWG.</p>	<p>Drawn By: S.JOHNSON</p>	<p>Date: 11-18-02</p>
<p>ETCO Incorporated Engineered Products 25 Bellows Street Warwick, RI 02888 Phone: (401) 467-2400 Fax: (401) 467-9230 www.ETCO.com</p>		<p>Chk'd/App'd By:</p>	<p>Scale: 10X</p>	<p>Size <b>B</b></p>
		<p>Dwg. No.: <b>S112N cust</b></p>		