

NOTE:

- 1.) MAT'L: .020 THK., BRASS, #2 TEMPER (HALF HARD), PER ETCO METAL CODE NO. 00310.
- 2.) MAT'L: .020 THK., PRE-TINNED BRASS, #2 TEMPER (HALF HARD), PER ETCO METAL CODE NO. 01390.
- 3.) PARTS MAY BE COATED WITH A LIGHT FILM OF LUBRICATION USED IN THE MANUFACTURING PROCESS.
- 4.) WIRE RANGE: 20-16 AWG.

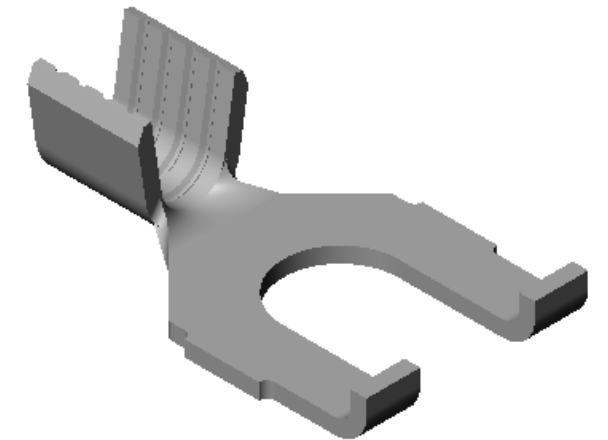
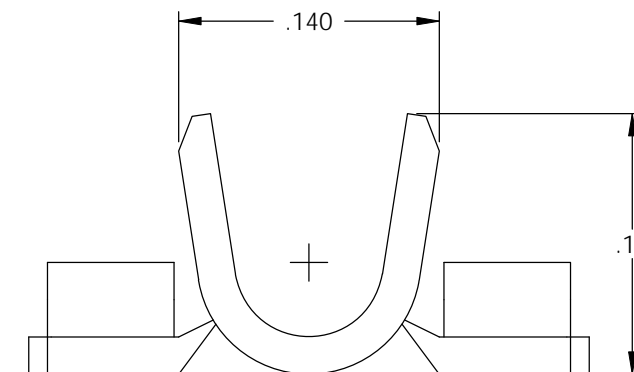
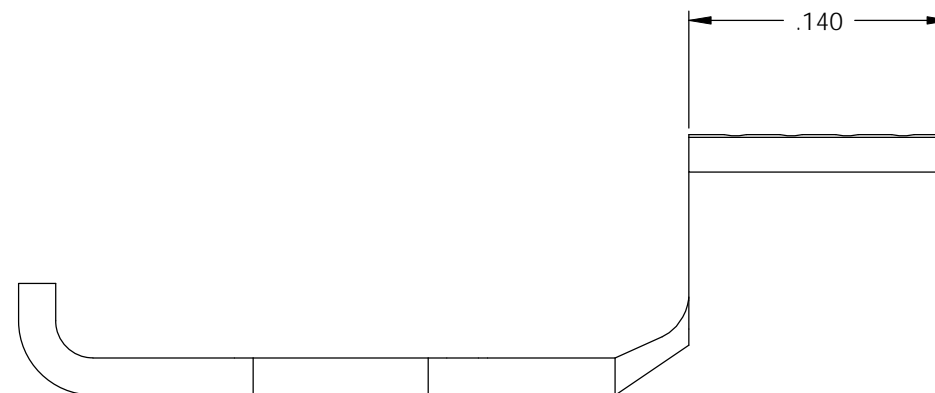
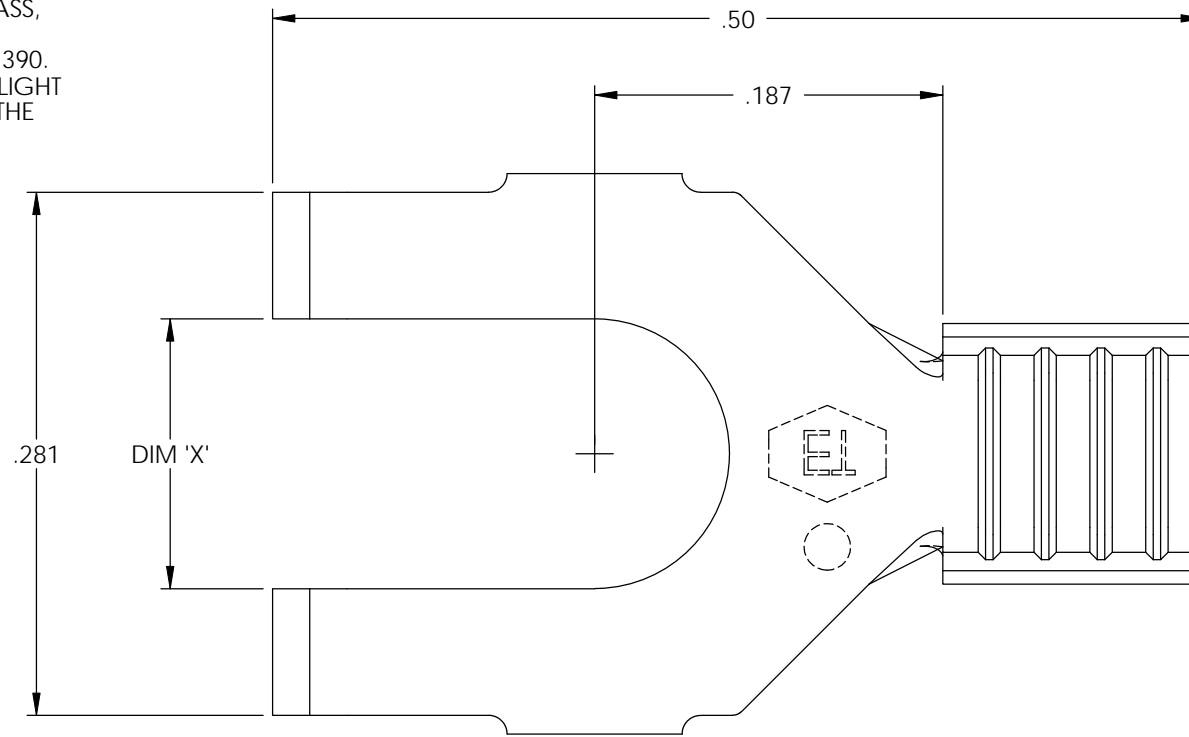

P/C	DESCRIPTION	DIM 'X'	MAT'L	UL	SP
03350	S116-4-HB	.119	NOTE 1	X	X
03360	S116-4-THB	.119	NOTE 2	X	X
03370	S116-6-HB	.145	NOTE 1	X	X
03380	S116-6-THB	.145	NOTE 2	X	X
03390	S116-8-HB	.171	NOTE 1	X	X
03400	S116-8-THB	.171	NOTE 2	X	X

Rev.	Description of Change/ SCN#	Date
1	SCN# 102057 SCJ ORG.ENG.DWG.DATE: 1-20-93	11-7-02
2	ADDED P/Cs SCN#140162 SCJ	7-31-07

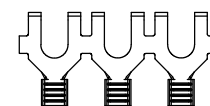
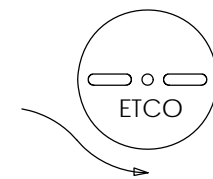
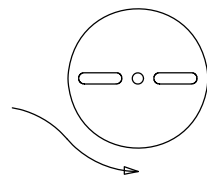

UNCONTROLLED COPY

<p>THIRD ANGLE PROJECTION TOLERANCES UNLESS OTHERWISE SPECIFIED INCHES: .XX - ±.030 .XXX - ±.015 ANGLES: ±5°</p>	<p>TOOL NO. 0060</p>	<p>Title: SPADE TERMINAL</p>		
		<p>DO NOT SCALE DWG.</p>	<p>Drawn By: S.JOHNSON</p>	<p>Date: 11-7-02</p>
<p>ETCO Incorporated Engineered Products 25 Bellows Street Warwick, RI 02888 Phone: (401) 467-2400 Fax: (401) 467-9230 www.ETCO.com</p>		<p>Chk'd/App'd By:</p>	<p>Scale: 10X</p>	<p>Size B</p>
		<p>Dwg. No.: S116 cust</p>		