

NOTE:

- 1.) MAT'L: .020 THK., BRASS, #2 TEMPER (HALF HARD), PER ETCO METAL CODE NO. 00280.
- 2.) MAT'L: .020 THK., PRE-TINNED BRASS, #2 TEMPER (HALF HARD), PER ETCO METAL CODE NO. 01350.
- 3.) MAT'L: .020 THK., PRE-NICKEL PLATED STEEL, #3 TEMPER (QUARTER HARD), PER ETCO METAL CODE NO. 03205.
- 4.) PARTS MAY BE COATED WITH A LIGHT FILM OF LUBRICATION USED IN THE MANUFACTURING PROCESS.
- 5.) WIRE RANGE: 20-16 AWG.

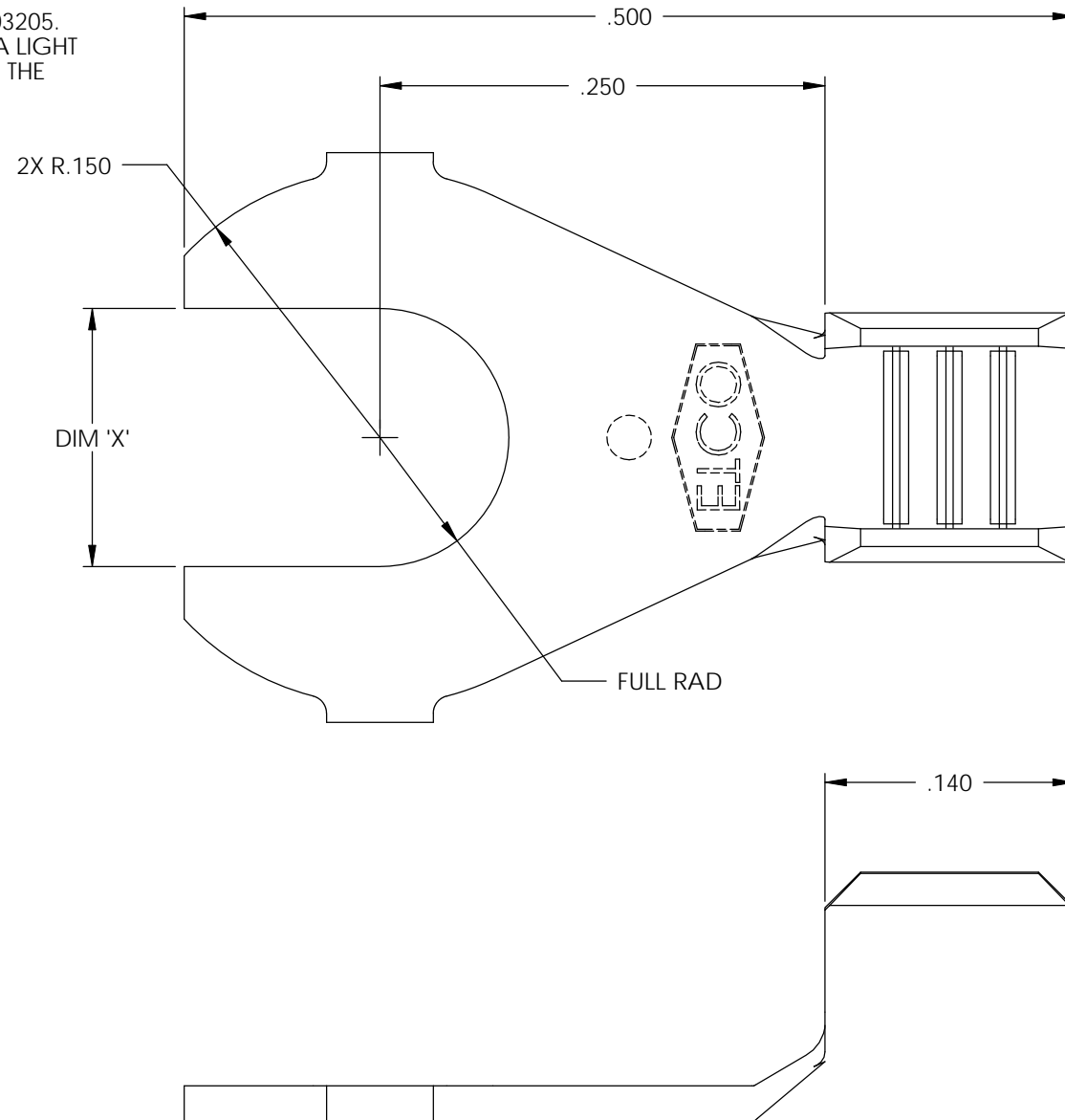

P/C	DESCRIPTION	DIM 'X'	MAT'L	UL	SP
03830	S176-4-HB	.119	NOTE 1	X	X
03840	S176-4-THB	.119	NOTE 2	X	X
03850	S176-6-HB	.145	NOTE 1	X	X
03860	S176-6-THB	.145	NOTE 2	X	X
03865	S176-6-NPS	.145	NOTE 3		
03870	S176-8-HB	.171	NOTE 1	X	X
03880	S176-8-THB	.171	NOTE 2	X	X
03885	S176-8-NPS	.171	NOTE 3		
03890	S176-10-HB	.197	NOTE 1	X	X
03900	S176-10-THB	.197	NOTE 2	X	X

Rev.	Description of Change/ SCN#	Date
1	REDRAWN ON SOLIDWORKS NO CHANGES SCJ ORG.ENG.DWG.DATE: 12-2-93	1-8-03
2	ADDED P/Cs SCN#140162 SCJ	8-21-07

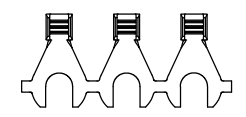
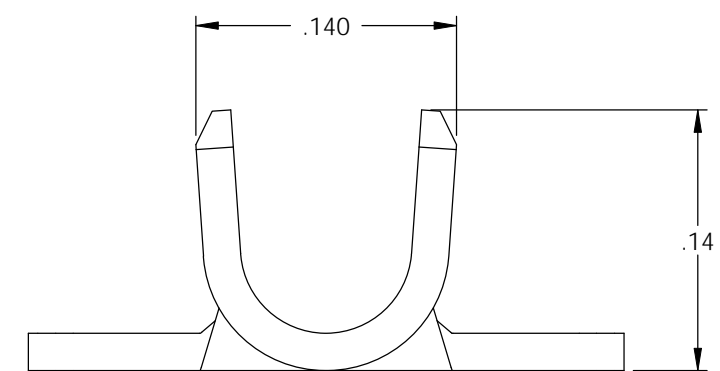
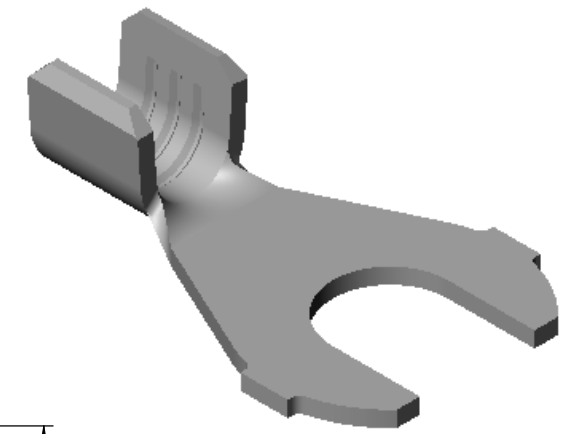

DIRECTION EXITING TOOL,
EARS UP, TO THE BACK

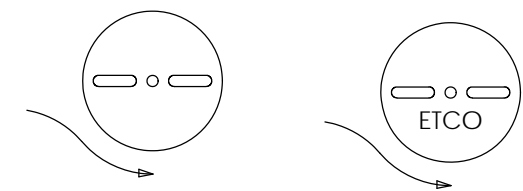

DIRECTION TOWARD APPLICATOR,
EARS UP, TO THE FRONT

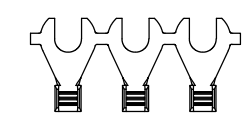

UNCONTROLLED COPY

<p>THIRD ANGLE PROJECTION TOLERANCES UNLESS OTHERWISE SPECIFIED INCHES: .XX - ±.030 .XXX - ±.015 ANGLES: ±5°</p>	<p>TOOL NO. 0063</p>	<p>Title: SPADE TERMINAL</p>		
		<p>DO NOT SCALE DWG.</p>	<p>Drawn By: S.JOHNSON</p>	<p>Date: 1-8-03</p>
<p>ETCO Incorporated Engineered Products 25 Bellows Street Warwick, RI 02888 Phone: (401) 467-2400 Fax: (401) 467-9230 www.ETCO.com</p>		<p>Chk'd/App'd By:</p>	<p>Scale: 10X</p>	<p>Size B</p>
		<p>Dwg. No.: S176 cust</p>		