

NOTES:

1. MATERIAL: .020 THICK, ELECTRO-GALVANIZED ZINC <sup>③</sup> PLATED STEEL, #3 TEMPER (1/4 HARD) PER ETCO METAL CODE 0-0103.
2. MATERIAL: .020 THICK, S430 STAINLESS STEEL, BRIGHT ANNEALED, PER ETCO METAL CODE 0-0053.
3. PARTS MAY BE COATED WITH A LIGHT FILM OF LUBRICATION USED IN THE MANUFACTURING PROCESS.
4. WIRE RANGE: 8mm.

P/C	DESCRIPTION	MAT'L	CLIP	REWIND
15208	SP25-SS-T	NOTE 2	SCA4-B	NO
15251	SP25-BZS-T	NOTE 1	SCA4-B	NO
15355	SP25-BZS-T-R	NOTE 1	SCA4-B	YES

Rev.	Description of Change/ SCN#	Date
3	ECR# 4870 SCJ Redrawn in SW from ACAD Org.Eng.Dwg.Date: 2/20/98	1/28/19

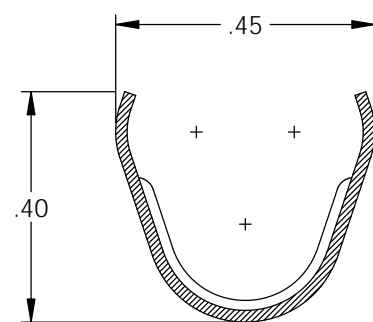
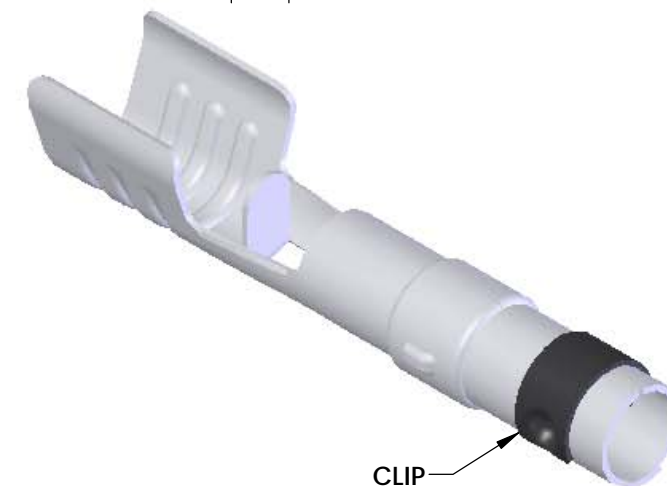

SECTION B-B

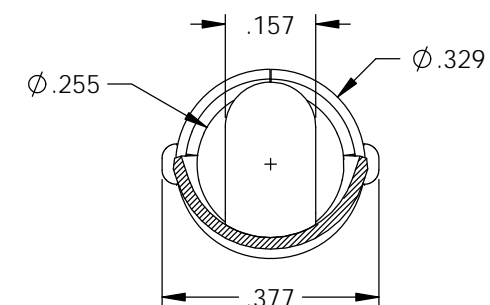
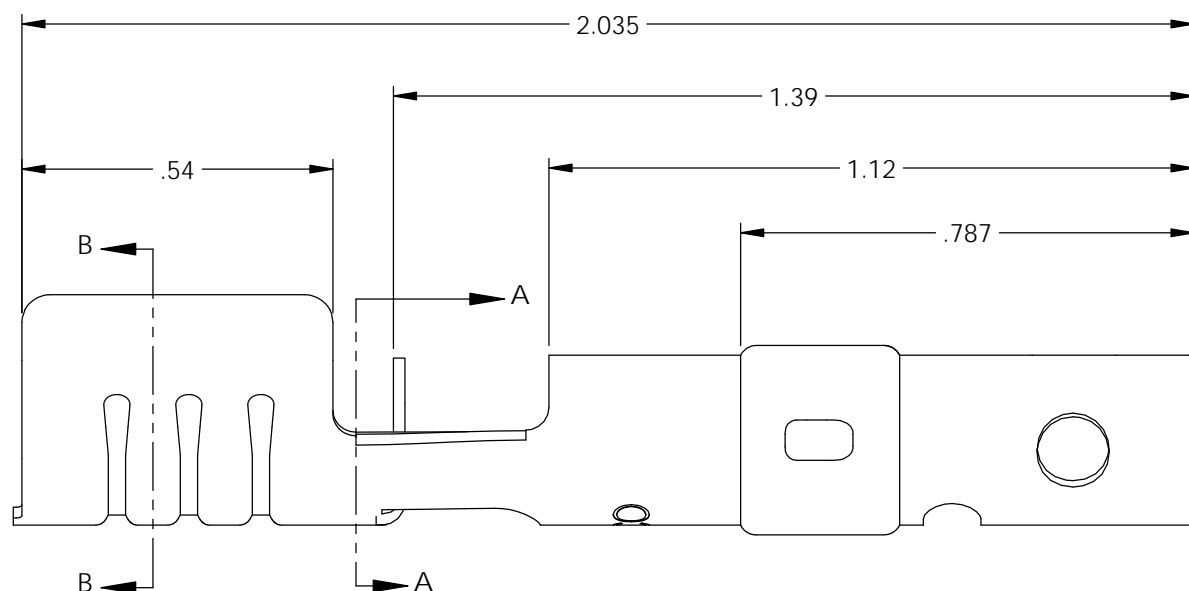
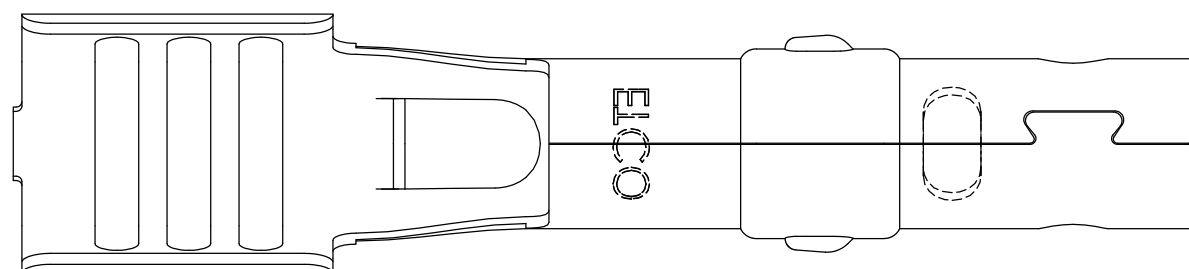

SECTION A-A

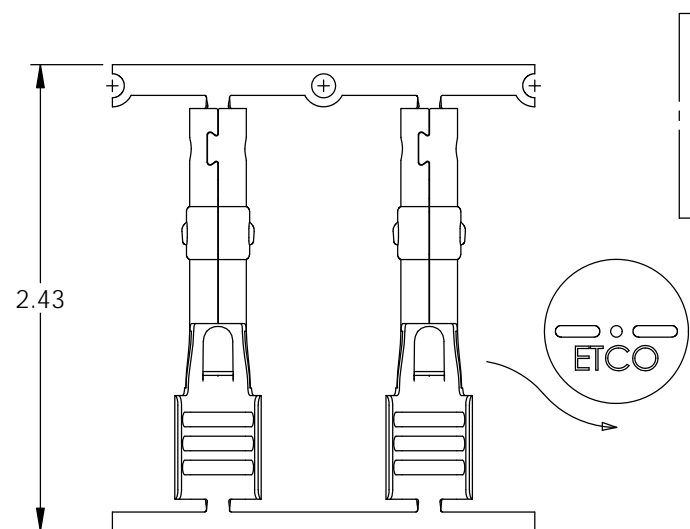

DIRECTION EXITING TOOL, EARS UP TO THE FRONT

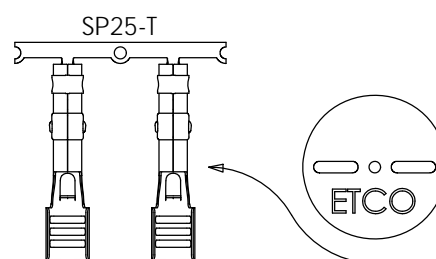
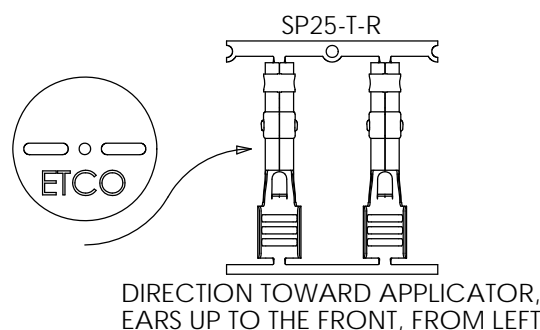
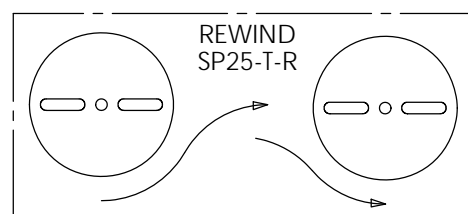

DIRECTION TOWARD APPLICATOR, EARS UP TO THE FRONT, FROM RIGHT

THIS PRINT IS THE PROPERTY OF ETCO INCORPORATED. NO PART OF THIS DESIGN MAY BE USED IN ANY WAY WITHOUT WRITTEN CONSENT FROM ETCO INCORPORATED.

# UNCONTROLLED COPY

<p>THIRD ANGLE PROJECTION TOLERANCES UNLESS OTHERWISE SPECIFIED INCHES: .XX - ±.030 .XXX - ±.015 ANGLES: ±5°</p>	<p>TOOL NO. <b>2087</b></p>	<p>Title: <b>Spark Plug Terminal</b></p>	
		<p>DO NOT SCALE DWG.</p>	<p>Drawn By: <b>S.Johnson</b></p>
<p>Design Control By: <b>ETCO</b></p>		<p>Scale: <b>3X</b></p>	<p>Size: <b>B</b></p>
<p>Dwg. No.: <b>SP25-T cust</b></p>		<p>ETCO Incorporated Engineered Products 25 Bellows Street Warwick, RI 02888 Phone: (401) 467-2400 Fax: (401) 467-9230 www.ETCO.com</p>	