

NOTES:

1. MATERIAL: .020 THICK S430 STAINLESS STEEL, ANNEALED TO TEMPER, PER ETCO METAL CODE 0-0050.
2. PARTS MAY BE COATED WITH A LIGHT FILM OF LUBRICATION USED IN THE MANUFACTURING PROCESS.
3. WIRE RANGE: 8mm.

P/C	DESCRIPTION	MAT'L	CLIP
22031	SP362-SS	NOTE 1	SCA570

Rev.	Description of Change/ SCN#	Date
1	Redrawn in SW from ACAD Org.Eng.Dwg.Date: 11/05/02	1/03/19

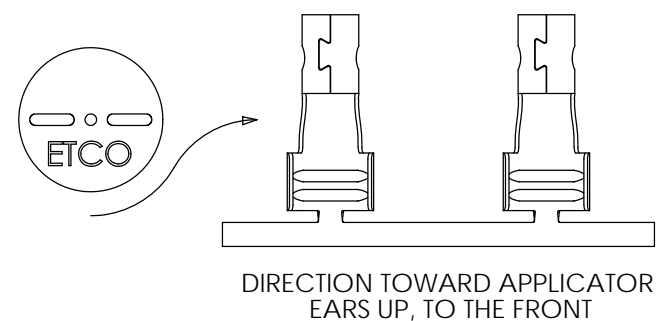
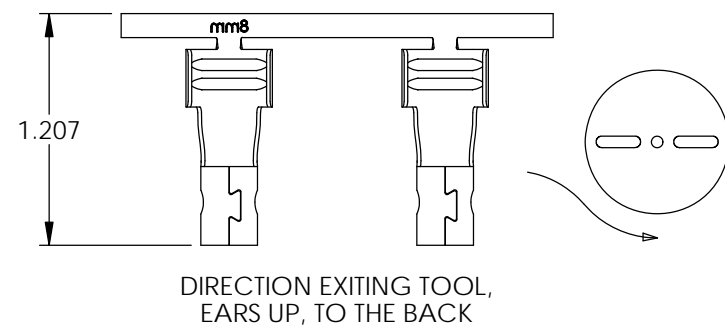
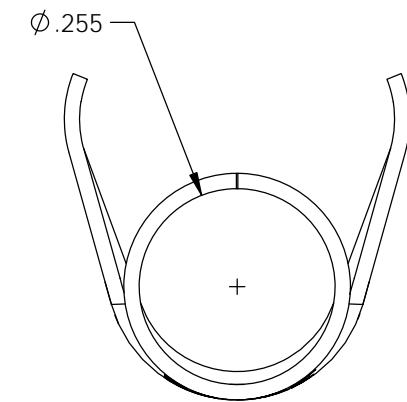
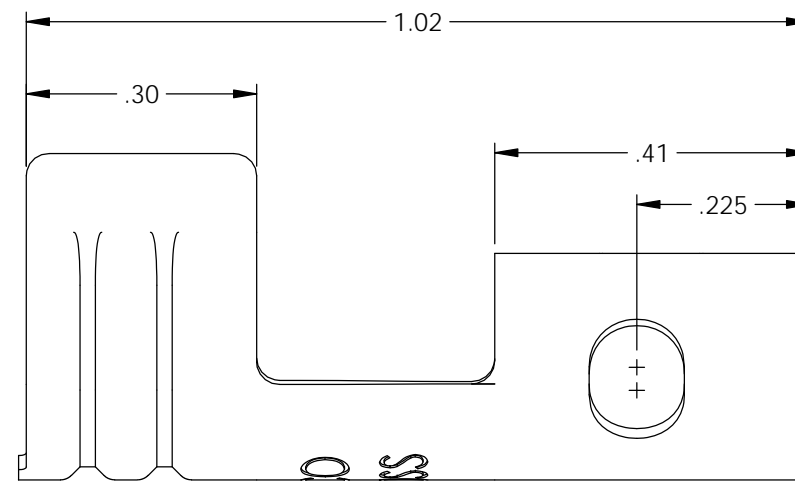
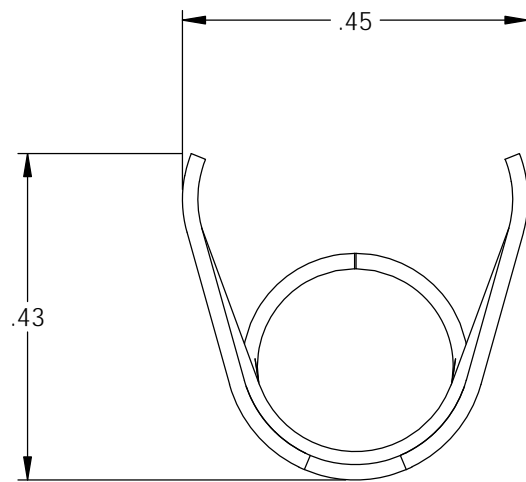
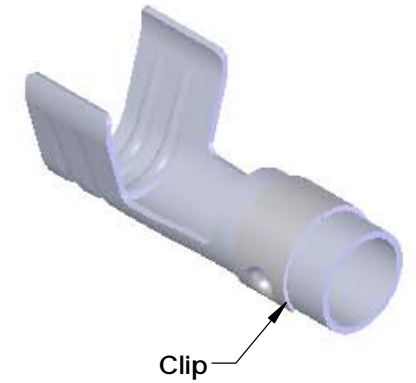
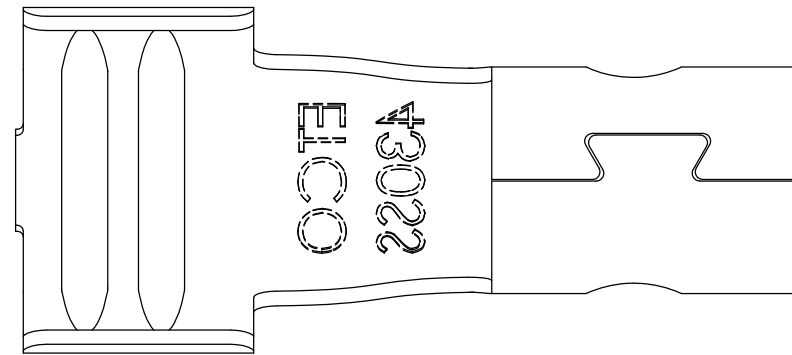

UNCONTROLLED COPY

<p>THIRD ANGLE PROJECTION TOLERANCES UNLESS OTHERWISE SPECIFIED INCHES: .XX - ±.030 .XXX - ±.015 ANGLES: ±5°</p>	<p>TOOL NO. 2086 2060</p>	<p>Title: Spark Plug Terminal</p>		
		<p>DO NOT SCALE DWG.</p>	<p>Drawn By: S.Johnson</p>	<p>Date: 1/03/19</p>
<p>ETCO Incorporated Engineered Products 25 Bellows Street Warwick, RI 02888 Phone: (401) 467-2400 Fax: (401) 467-9230 www.ETCO.com</p>		<p>Design Controlled By: ETCO</p>	<p>Scale: 4X</p>	<p>Size B</p>
		<p>Dwg. No.: SP362 cust</p>		