

NOTES:

1. MATERIAL: .020 THICK, ELECTRO-GALVANIZED ZINC PLATED STEEL, #3 TEMPER (1/4 HARD) PER ETCO METAL CODE 0-0034.
2. MATERIAL: .020 THICK, S430 STAINLESS STEEL, BRIGHT ANNEALED, PER ETCO METAL CODE 0-0051.
3. PARTS MAY BE COATED WITH A LIGHT FILM OF LUBRICATION USED IN THE MANUFACTURING PROCESS.
4. WIRE RANGE: 8mm CABLE.

P/C	DESCRIPTION	MAT'L	CLIP
15276	SP858-ZPS	NOTE 1	SCA4-MB
15135	SP858-SS	NOTE 2	SCA4-B

Rev.	Description of Change/ SCN#	Date
1	ECR# 4870 SCJ Redrawn in SW from ACAD Org.Eng.Dwg. Date: 6/06/94	9/28/18

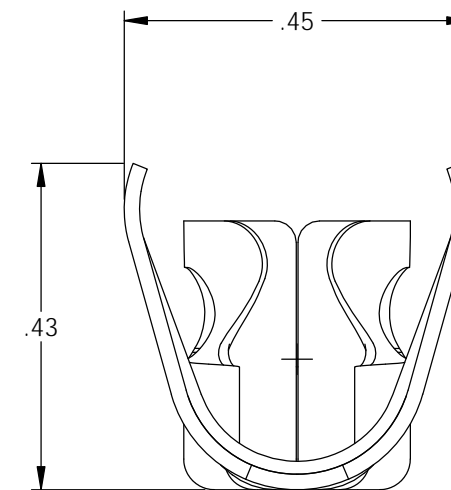
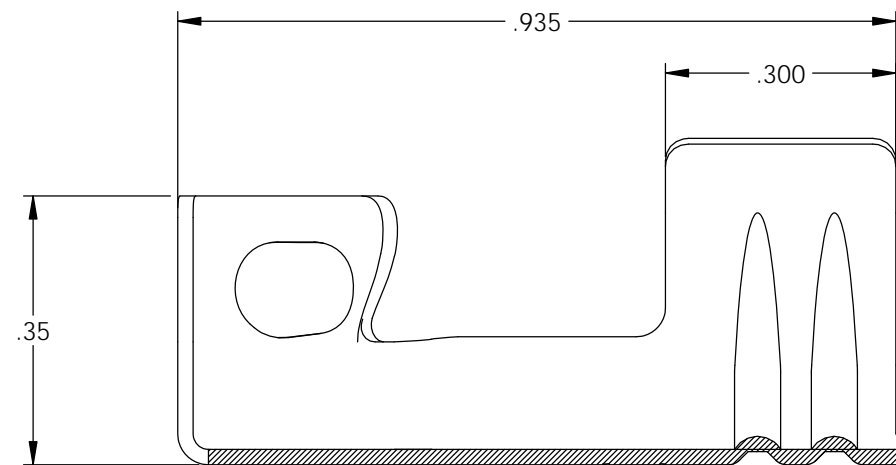
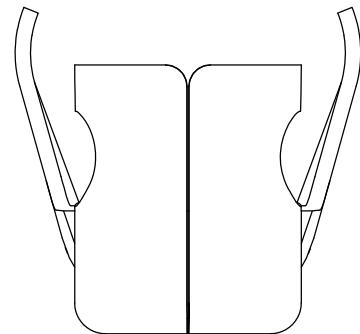
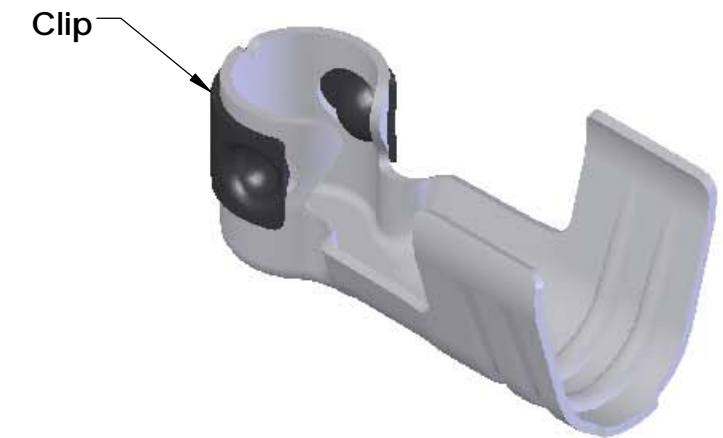
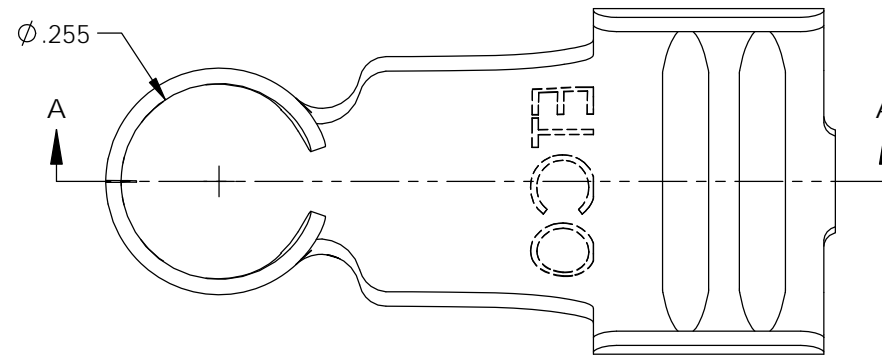

SECTION A-A

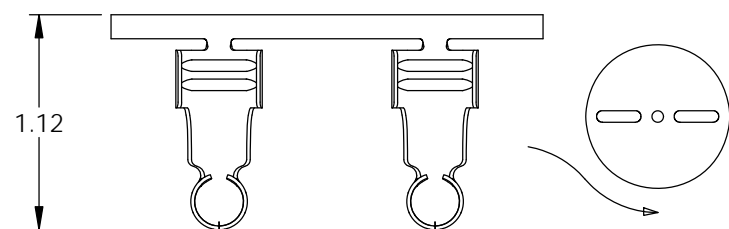

DIRECTION EXITING TOOL,
EARS UP, TO THE BACK

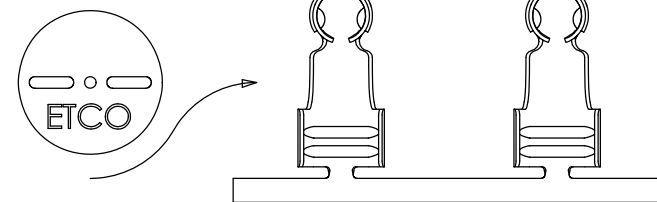

DIRECTION TOWARD APPLICATOR,
EARS UP, TO THE FRONT

UNCONTROLLED COPY

<p>THIRD ANGLE PROJECTION TOLERANCES UNLESS OTHERWISE SPECIFIED INCHES: .XX - ±.030 .XXX - ±.015 ANGLES: ±5°</p>	<p>TOOL NO. 2183</p>	<p>Title: 90° Ignition Terminal: 8mm</p>		
		<p>DO NOT SCALE DWG.</p>	<p>Drawn By: S.Johnson</p>	<p>Date: 9/28/18</p>
<p>ETCO Incorporated Engineered Products 25 Bellows Street Warwick, RI 02888 Phone: (401) 467-2400 Fax: (401) 467-9230 www.ETCO.com</p>		<p>Design Control By: ETCO</p>	<p>Scale: 4X</p>	<p>Size B</p>
		<p>Dwg. No.: SP858 cust</p>		