

NOTES:

1. MATERIAL: .020 THICK, ELECTRO-GALVANIZED ZINC <sup>①</sup> PLATED STEEL, #3 TEMPER (1/4 HARD) PER ETCO METAL CODE 0-0103.
2. MATERIAL: .020 THICK, S430 STAINLESS STEEL, BRIGHT ANNEALED, PER ETCO METAL CODE 0-0053.
3. PARTS MAY BE COATED WITH A LIGHT FILM OF LUBRICATION USED IN THE MANUFACTURING PROCESS.
4. WIRE RANGE: 8mm.

P/C	DESCRIPTION	MAT'L	CLIP	REWIND
15289	SP954-SS	NOTE 2	SCA4-G	NO
15295	SP954-SS-R	NOTE 2	SCA4-G	YES

Rev.	Description of Change/ SCN#	Date
1	ECR# 4870 SCJ Redrawn in SW from ACAD Org.Eng.Dwg.Date: 8/25/04	11/27/18

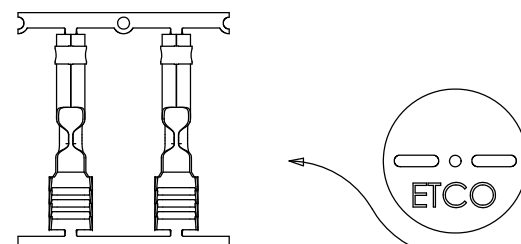
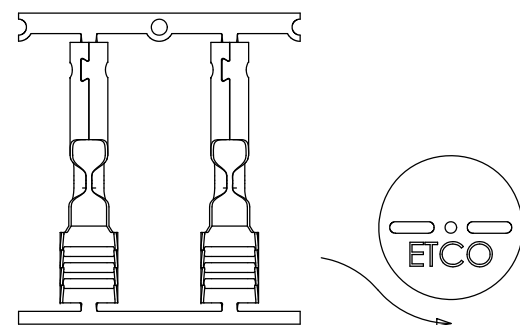
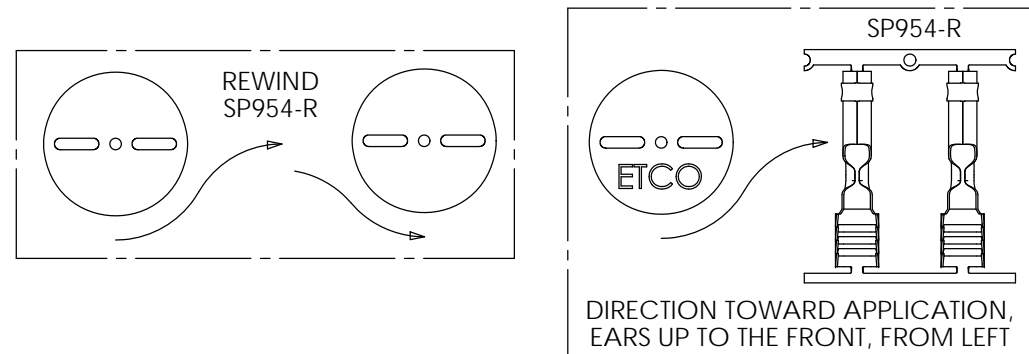
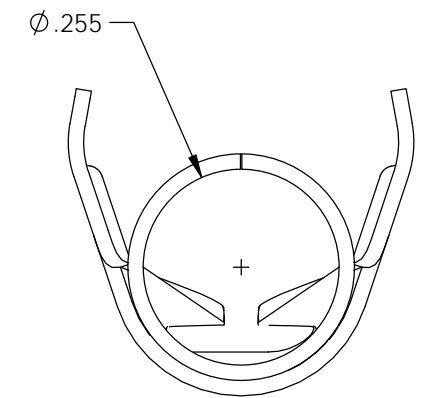
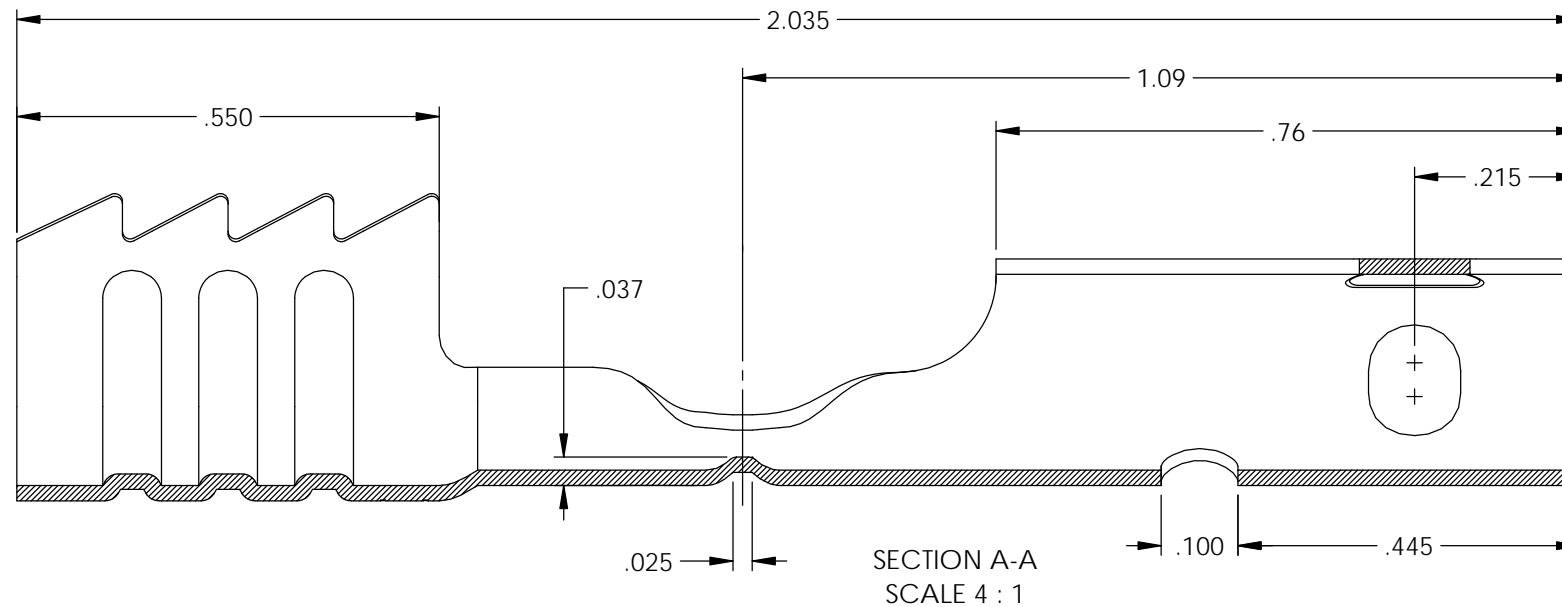
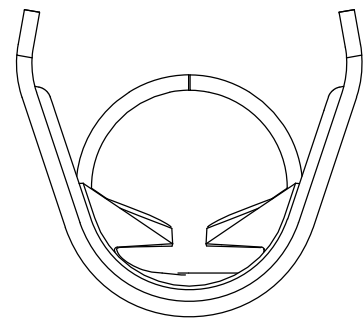
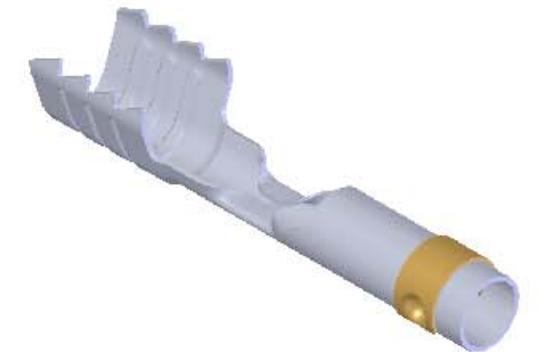
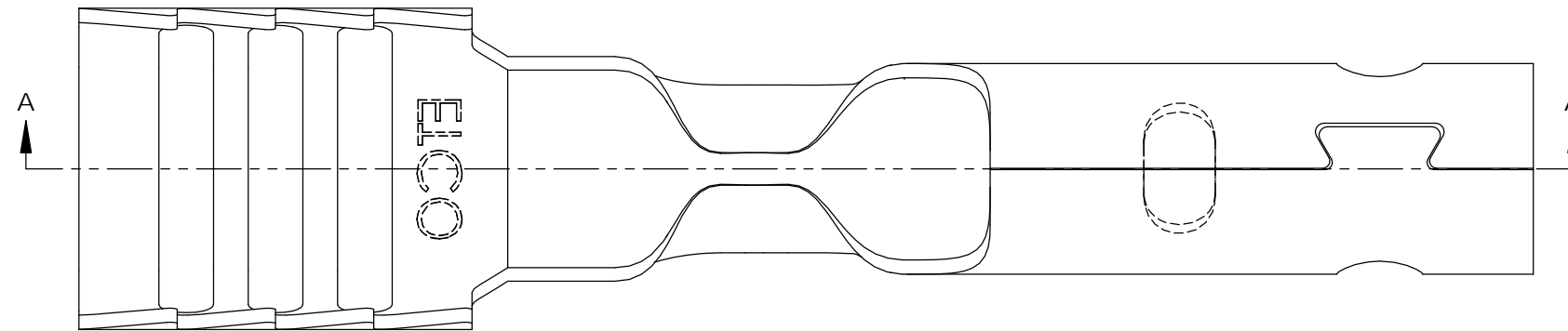

# UNCONTROLLED COPY

<p>THIRD ANGLE PROJECTION TOLERANCES UNLESS OTHERWISE SPECIFIED INCHES: .XX - ±.030 .XXX - ±.015 ANGLES: ±5°</p>	TOOL NO. <b>2035</b>	Title: <b>Spark Plug Terminal</b>	
		DO NOT SCALE DWG.	Drawn By: <b>S.Johnson</b> Date: <b>11/27/18</b>
ETCO Incorporated Engineered Products 25 Bellows Street Warwick, RI 02888 Phone: (401) 467-2400 Fax: (401) 467-9230 www.ETCO.com		Design Controlled By: <b>ETCO</b>	Scale: <b>4X</b>
		Dwg. No.: <b>SP954 cust</b>	