

NOTES:

1. MATERIAL: .020 THICK, ELECTRO-GALVANIZED ZINC ^① PLATED STEEL, #3 TEMPER (1/4 HARD) PER ETCO METAL CODE 0-0103.
2. MATERIAL: .020 THICK, S430 STAINLESS STEEL, BRIGHT ANNEALED, PER ETCO METAL CODE 0-0053.
3. PARTS MAY BE COATED WITH A LIGHT FILM OF LUBRICATION USED IN THE MANUFACTURING PROCESS.
4. WIRE RANGE: 8mm.

P/C	DESCRIPTION	MAT'L	CLIP	REWIND
15271	SP985-SS-R	NOTE 2	SCA4-TR	YES

Rev.	Description of Change/ SCN#	Date
1	ECR# 4870 & 5356 SCJ Redrawn in SW from ACAD Org.Eng.Dwg.Date: 12/21/89	11/27/18

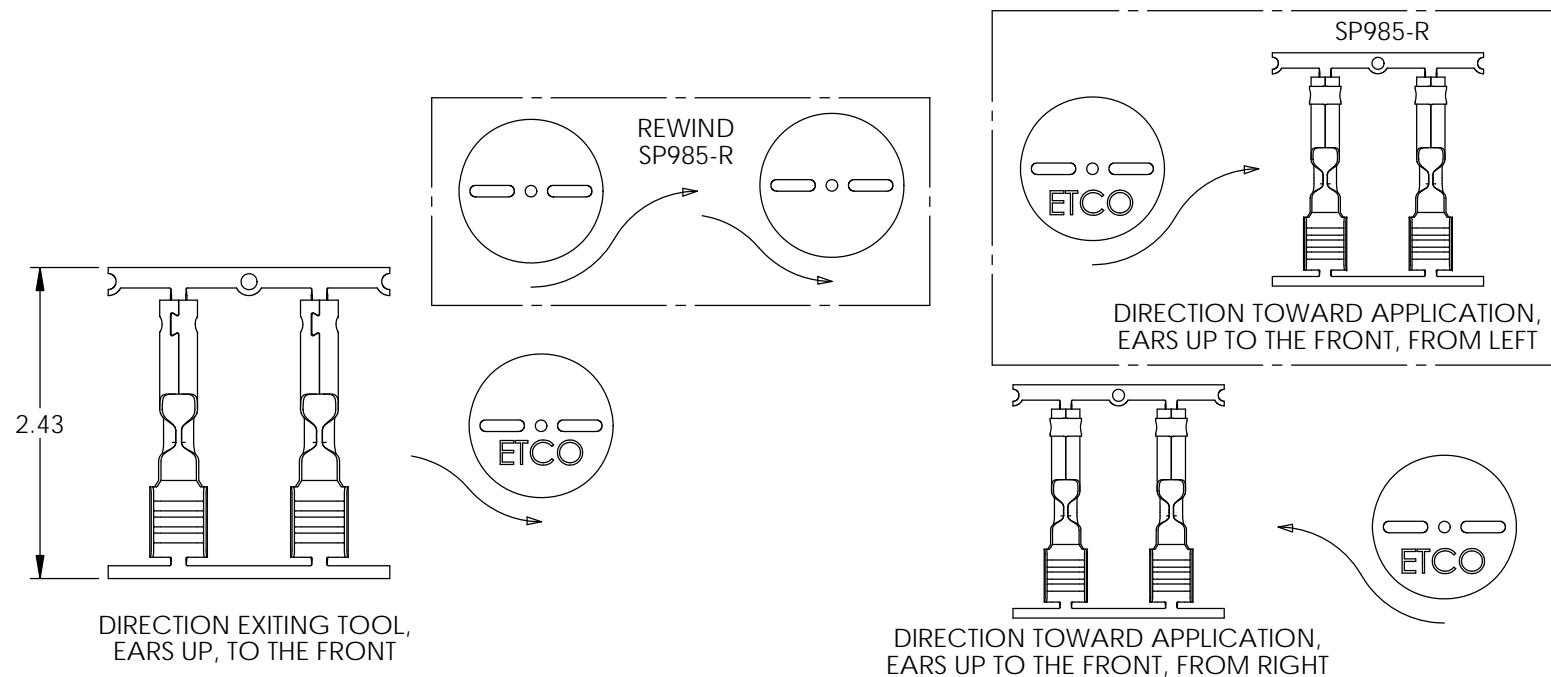
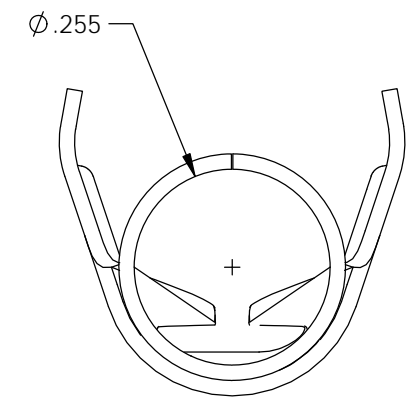
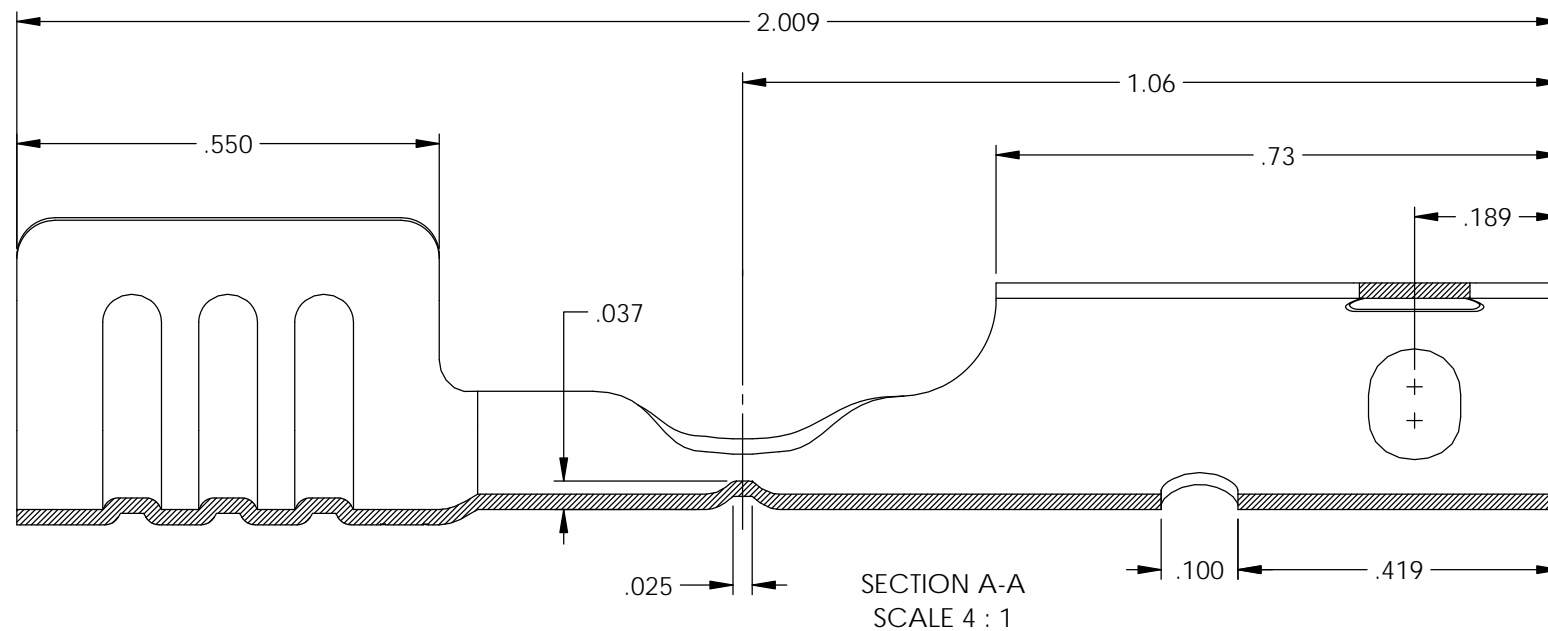
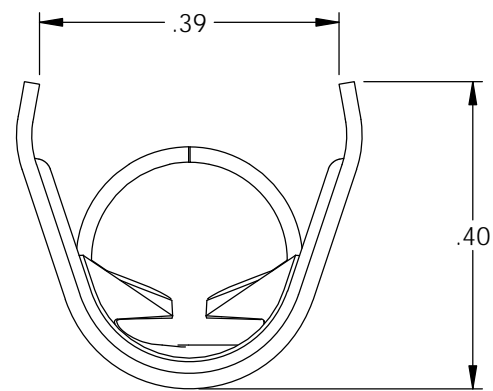
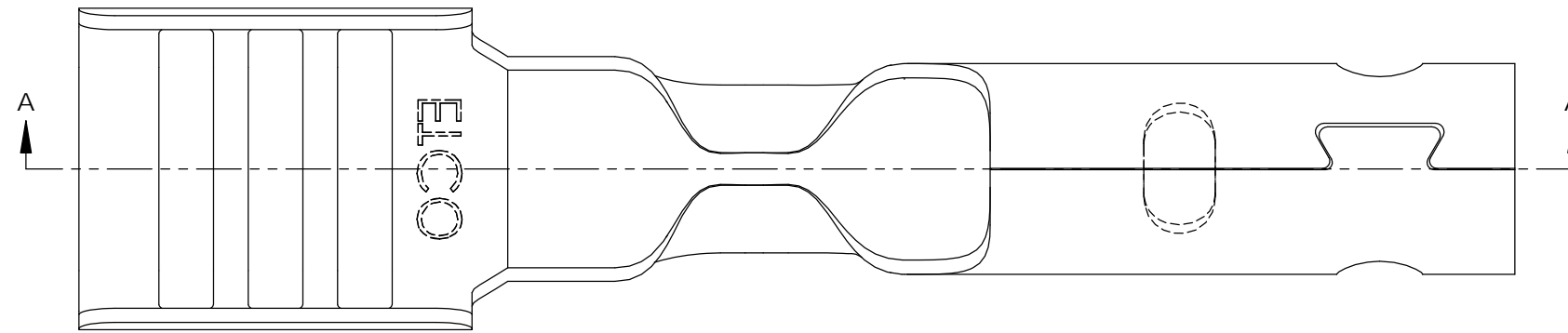

UNCONTROLLED COPY

<p>THIRD ANGLE PROJECTION TOLERANCES UNLESS OTHERWISE SPECIFIED INCHES: .XX - ±.030 .XXX - ±.015 ANGLES: ±5°</p>	<p>TOOL NO.</p> <p>2035</p>	<p>Title:</p> <p>Spark Plug Terminal</p>	
		<p>DO NOT SCALE DWG.</p> <p>Design Controlled By: ETCO</p> <p>Dwg. No.: SP985 cust</p>	<p>Drawn By: S.Johnson</p> <p>Scale: 4X</p> <p>Date: 11/27/18</p> <p>Size: B</p>