

NOTES:

- 1. MATERIAL: .0275 THICK C26000 BRASS; 1/2 HARD ANNEALED TO TEMPER; PER ETCO METAL CODE 00205.
- 2. FOR WINDING AND REWINDING INSTRUCTIONS SEE PR-3-07.
- 3. WIRE RANGE: 20 - 18 AWG

PART CODE	DESCRIPTION (3)	MATERIAL	REWIND
14064	SRA7L-A-HB	NOTE 1	NO
14065	SRA7R-ARB-HB	NOTE 1	YES

Rev.	Description of Change/ SCN#	Date
1	Initial Release JPD	8/14/07
2	SCN-140386 JMR	6/10/08
3	ECR# 816 SCJ	10-27-11

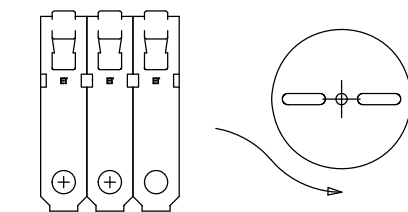
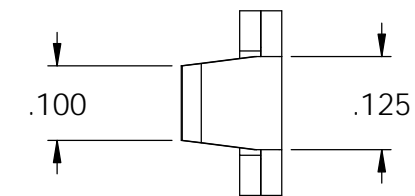
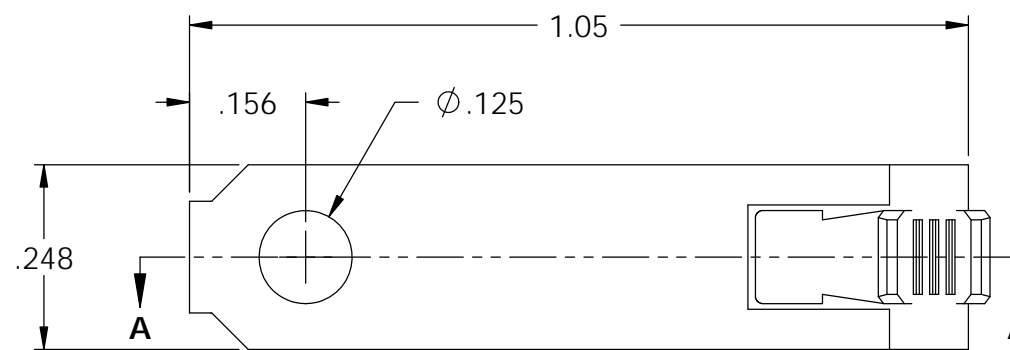
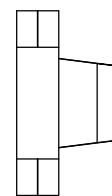
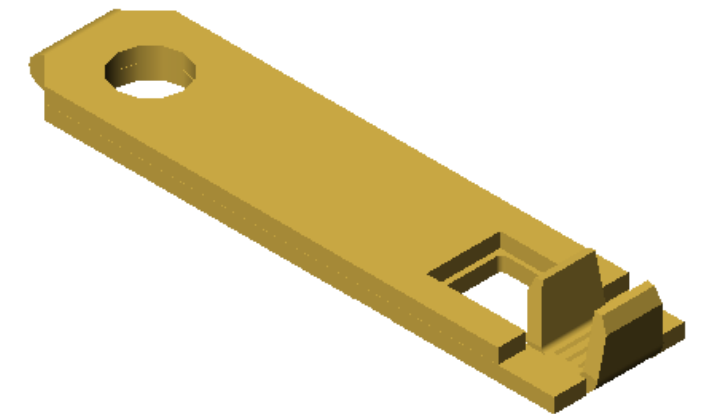
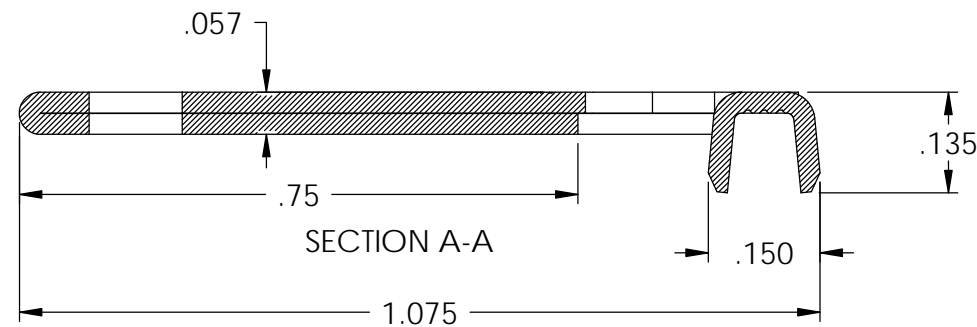
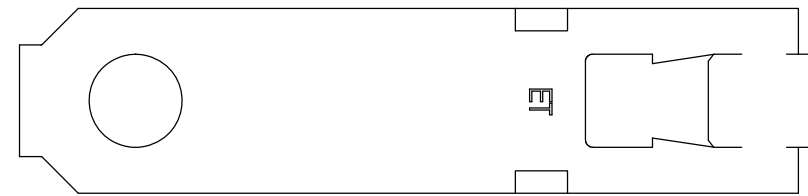

DIRECTION EXITING TOOL  
EARS DOWN, TO THE BACK  
SEE NOTE 2

THIS PRINT IS THE PROPERTY OF ETCO INCORPORATED. NO PART OF THIS DESIGN MAY BE USED IN ANY WAY WITHOUT WRITTEN CONSENT FROM ETCO INCORPORATED.

# UNCONTROLLED COPY

<p>THIRD ANGLE PROJECTION TOLERANCES UNLESS OTHERWISE SPECIFIED INCHES: .XX - ±.030 .XXX - ±.015 ANGLES: ±5°</p>	<p>TOOL NO. <b>0890</b></p>	<p>Title: <b>Right Angle Blade</b></p>		
		<p>DO NOT SCALE DWG.</p>	<p>Drawn By: <b>J. DeSio</b></p>	<p>Date: <b>8-14-07</b></p>
<p>ETCO Incorporated Engineered Products 25 Bellows Street Warwick, RI 02888 Phone: (401) 467-2400 Fax: (401) 467-9230 www.ETCO.com</p>		<p>Chk'd/App'd By:</p>	<p>Scale: <b>4X</b></p>	<p>Size <b>B</b></p>
		<p>Dwg. No.: <b>SRA7 cust</b></p>		