

NOTE:

- 1.) MAT'L: .010 THK., BRASS,  
#4 TEMPER (FULL HARD),  
PER ETCO METAL CODE NO. 00074.
- 2.) PARTS MAY BE COATED WITH A LIGHT  
FILM OF LUBRICATION USED IN THE  
MANUFACTURING PROCESS.
- 3.) WIRE RANGE: 27 AWG.
- 4.) INSUL RANGE:  $\varnothing$ .040.

P/C	DESCRIPTION	REWIND
10136	TS-1-R-HB	NO
10137	TS-1-L-HB	YES

Rev.	Description of Change/ SCN#	Date
2	REDRAWN ON SOLIDWORKS NO CHANGES SCJ ORG.ENG.DWG.DATE: 2-20-91	12-20-05

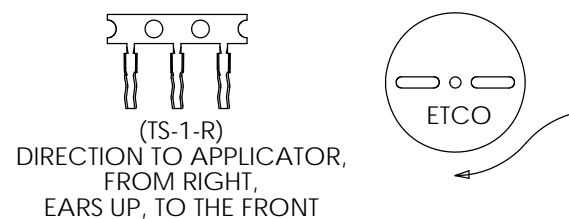
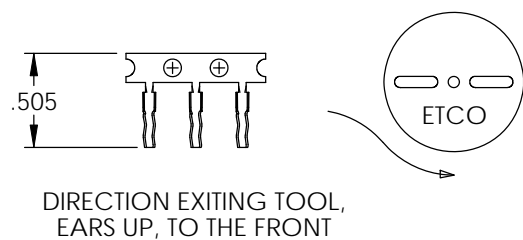
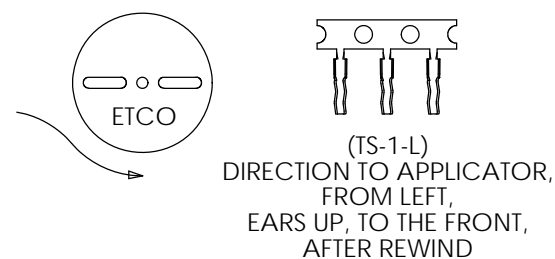
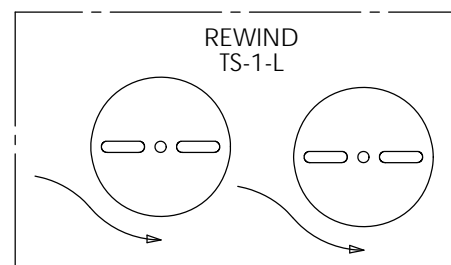
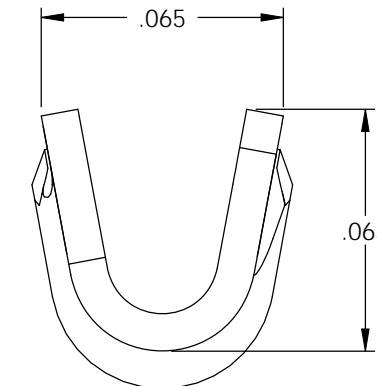
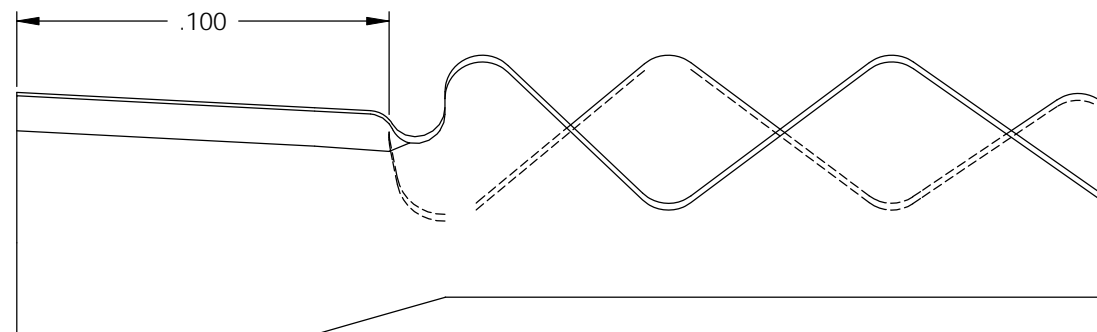
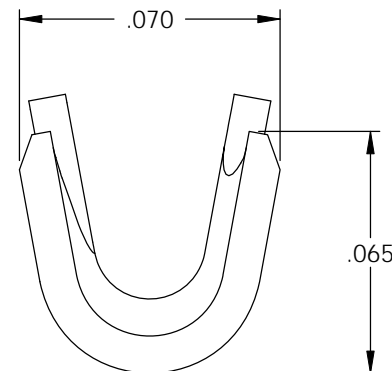
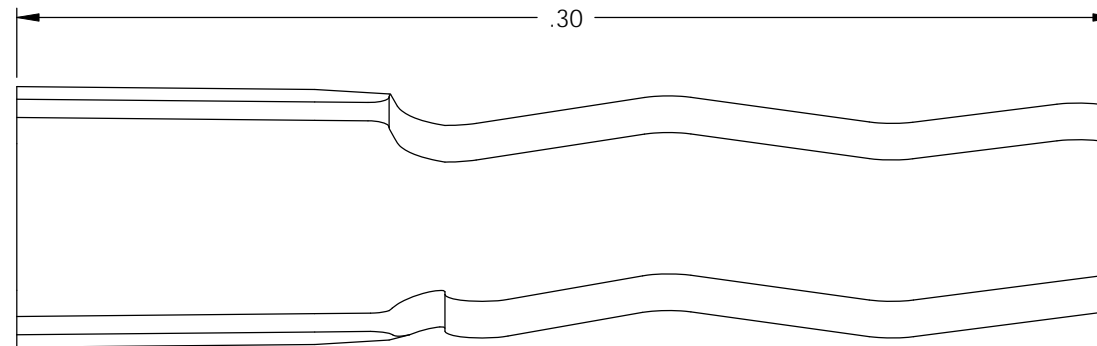

# UNCONTROLLED COPY

<p>THIRD ANGLE PROJECTION TOLERANCES UNLESS OTHERWISE SPECIFIED INCHES: .XX - <math>\pm</math>.030 .XXX - <math>\pm</math>.015 ANGLES: <math>\pm</math>5°</p>	TOOL NO. <b>0243</b>	Title: <b>TELEPHONE SPLICE</b>	
		DO NOT SCALE DWG.	Drawn By: S.JOHNSON
ETCO Incorporated Engineered Products 25 Bellows Street Warwick, RI 02888 Phone: (401) 467-2400 Fax: (401) 467-9230 www.ETCO.com		Chk'd/App'd By:	Scale: 20X
		Dwg. No.:	<b>TS-1</b>