

NOTE:

- 1.) MAT'L: .020 THK., BRASS, HALF HARD, ANNEALED TO TEMPER, PER ETCO METAL CODE NO. 00250.
- 2.) MAT'L: .020 THK., PRE-TINNED BRASS, HALF HARD, ANNEALED TO TEMPER, PER ETCO METAL CODE NO. 01315.
- 3.) MAT'L: .020 THK., PRE-NICKEL PLATED STEEL, #3 TEMPER (QUARTER HARD), PER ETCO METAL CODE NO. 03190.
- 4.) PARTS MAY BE COATED WITH A LIGHT FILM OF LUBRICATION USED IN THE MANUFACTURING PROCESS.
- 5.) CMA RANGE = 500-1,000.

P/C	DESCRIPTION	MAT'L
09946	UB1-FC-HB	NOTE 1
09974	UB1-FC-NPS	NOTE 3

Rev.	Description of Change/ SCN#	Date
1	SCN# 102886 SCJ ORG.ENG.DWG.DATE: 10-28-92	3-11-05
2	SCN# 140411 JMR	8-05-08

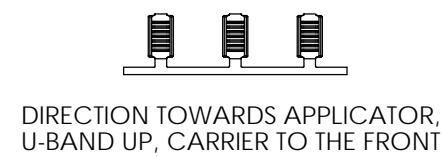
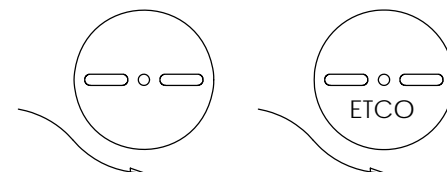
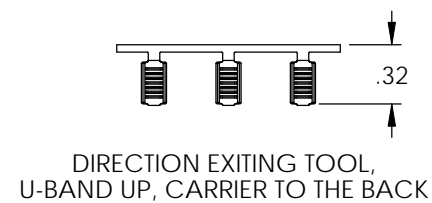
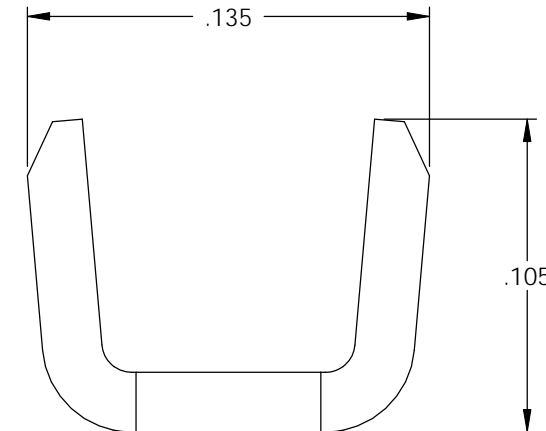
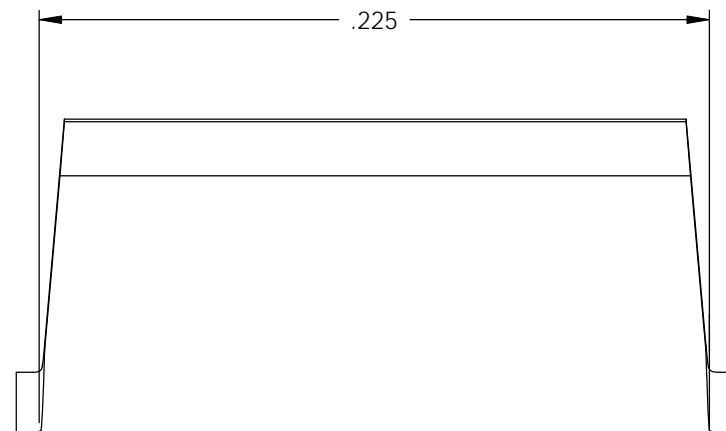
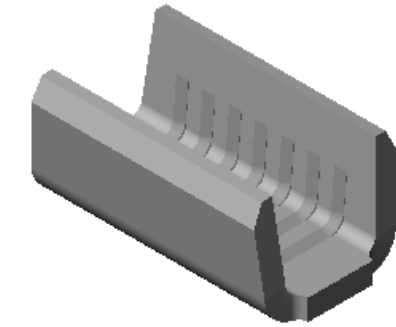
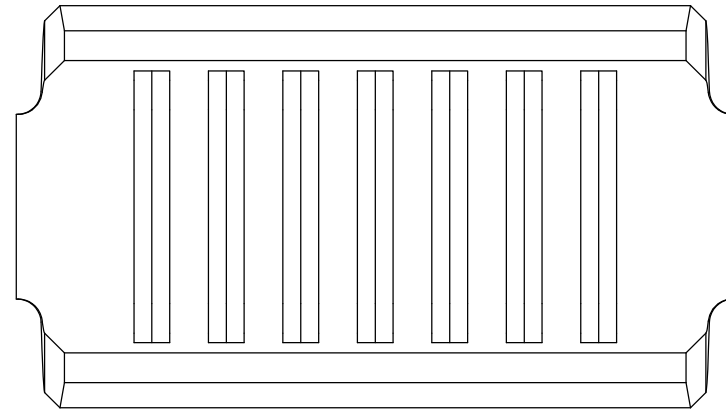

THIS PRINT IS THE PROPERTY OF ETCO INCORPORATED. NO PART OF THIS DESIGN MAY BE USED IN ANY WAY WITHOUT WRITTEN CONSENT FROM ETCO INCORPORATED.

UNCONTROLLED COPY

<p>THIRD ANGLE PROJECTION TOLERANCES UNLESS OTHERWISE SPECIFIED INCHES: .XX - ±.030 .XXX - ±.015 ANGLES: ±5°</p>	<p>TOOL NO. 0231</p>	<p>Title: U-BAND</p>		
		<p>DO NOT SCALE DWG.</p>	<p>Drawn By: S.JOHNSON</p>	<p>Date: 3-11-05</p>
<p>ETCO Incorporated Engineered Products 25 Bellows Street Warwick, RI 02888 Phone: (401) 467-2400 Fax: (401) 467-9230 www.ETCO.com</p>		<p>Chk'd/App'd By:</p>	<p>Scale: 16X</p>	<p>Size B</p>
		<p>Dwg. No.: UB1-FC cust</p>		